

Angetriebene Werkzeuge

CWS WERKZEUGMASCHINEN & SERVICE

CWS Werkzeugmaschinen & Service steht für Präzision, Qualität und Langlebigkeit von CNC-Werkzeugmaschinen. Neben dem Vertrieb und Verkauf der Swiss-Type-Maschinen, versteht sich CWS Werkzeugmaschinen & Service darüber hinaus als Dienstleister in Sachen Service für Ihre qualitativ hochwertige Produktion mit CNC-Drehmaschinen. Aus diesem Grund setzt CWS Werkzeugmaschinen & Service nicht nur auf die Kompetenz unserer Mitarbeiter, sondern wir arbeiten präzise, zuverlässig und termingenau.

CWS Werkzeugmaschinen & Service hat seinen Firmensitz in Denkingen in Baden-Württemberg. Gegründet als CWS Aldingen hat CWS Werkzeugmaschinen & Service heute viele namhafte Hersteller von CNC Werkzeugmaschinen im Sortiment und ist überdies hinaus Generalvertreter des südkoreanischen Hersteller Nexturn in Deutschland.

Neben dem Verkauf und Vertrieb von Langdrehern und angetriebenen Werkzeugen, ist CWS Werkzeugmaschinen & Service Ihr Spezialist für die Wartung, Einrichtung und Reparatur von CNC-Maschinen aller Art und jedes Herstellers.

Unseren Service bieten wir für sämtliche CNC-Drehmaschinen mit Fanuc-, Siemens- und Mitsubishi-Steuerungen an.



UNSERE LEISTUNGEN

- Verkauf und Vertrieb von CNC-Maschinen und Zubehör
- Mechanische Reparatur (Alle Hersteller)
- PMC/SPS Software-Anpassungen (Nur Fanuc-Steuerungen)
- Automationsanbindung Sonderanbauten
- Elektronische Fehlersuche
- Antriebsspindelüberholung
- Kugelrollspindeltausch
- Maschinendurchsicht mit Prüfprotokoll
- Inbetriebnahme von Neu- und Gebrauchtmaschinen
- Schulungen für Fanuc, Mitsubishi (Diagnostik, PMC/Software-Programmierung, SPS)
- Drehteile: Programmierung und Einrichtung
- Erstellung hochkomplexer Makros
- weitere Leistungen rund um CNC-Drehmaschinen auf Anfrage



Contents

STAR	01~10
TSUGAMI	11~17
CINCOM	18~26
MIYANO	27~30
CHIAH CHYUN	31~33
NOMURA	34~36
HANWHA	37~39
JINN FA	40
DOOSAN	41
NAKAMURA	42

STAR

ECAS, SB, SR, SW

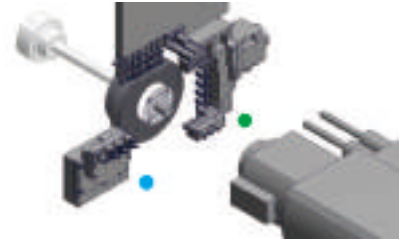

STAR

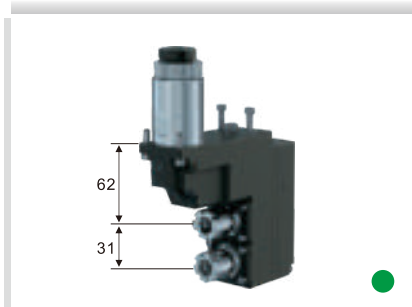

2-spindle drilling/milling unit

Product No.	STRA2A2204
Ref. No.	54151
Speed ratio	1:1
RPM Max.	6000
Tool clamping	ER16M

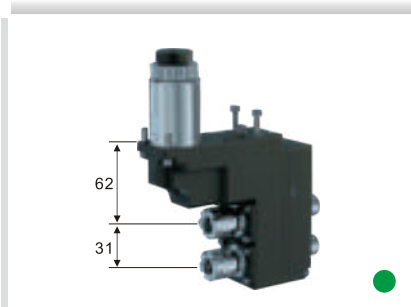

2-spindle double drilling/milling unit

Product No.	STRA2B2202
Ref. No.	66159
Speed ratio	1:1
RPM Max.	6000
Tool clamping	ER16M/ER11M

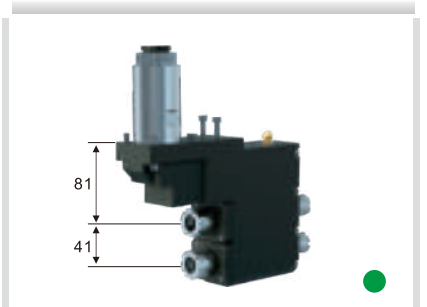

2-spindle double drilling/milling unit

Product No.	STRA2B2302
Ref. No.	10169
Speed ratio	1:1
RPM Max.	5000
Tool clamping	ER20M/ER16M

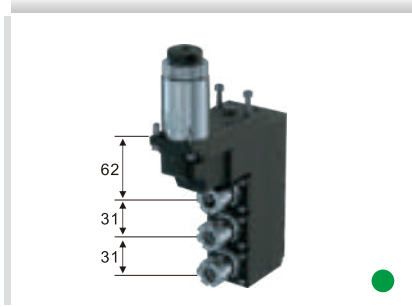

3-spindle drilling/milling unit

Product No.	STRA2A3201
Ref. No.	66151
Speed ratio	1:1
RPM Max.	6000
Tool clamping	ER16M

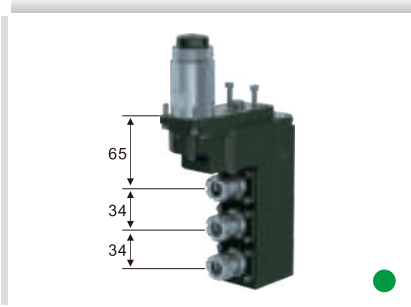

3-spindle drilling/milling unit

Product No.	STRA2A3301
Ref. No.	67151
Speed ratio	1:1
RPM Max.	6000
Tool clamping	ER16M

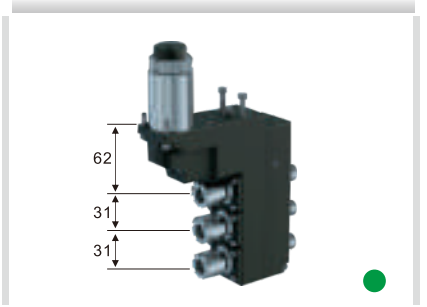

3-spindle double drilling/milling unit

Product No.	STRA2B3201
Ref. No.	67161
Speed ratio	1:1
RPM Max.	6000
Tool clamping	ER16M/ER11M

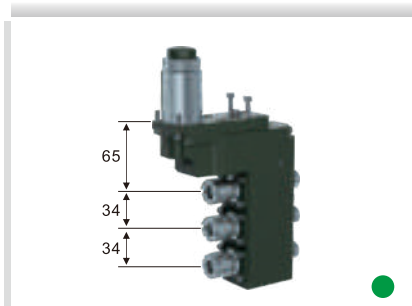

3-spindle double drilling/milling unit

Product No.	STRA2B3301
Ref. No.	67159
Speed ratio	1:1
RPM Max.	6000
Tool clamping	ER16M/ER11M

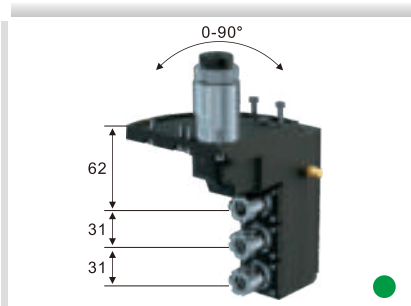

3-spindle drilling/milling unit

Product No.	STRA2A3202
Ref. No.	-
Speed ratio	1:1
RPM Max.	6000
Tool clamping	ER16M

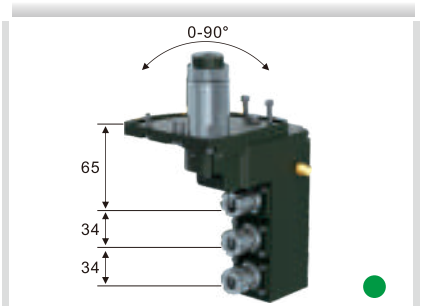

3-spindle drilling/milling unit

Product No.	STRA2A3302
Ref. No.	-
Speed ratio	1:1
RPM Max.	6000
Tool clamping	ER16M

Symbology



Internal Coolant/BAR



Speeder



Reducer



Adjustable

STAR

ECAS, SB, SR, SW

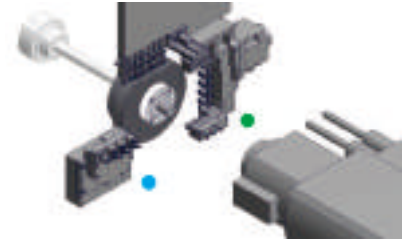

STAR

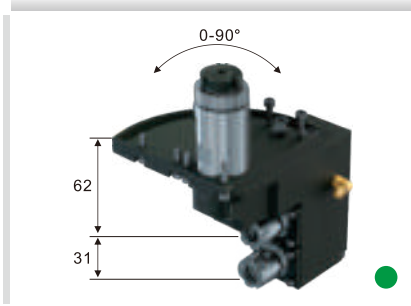

2-spindle drilling/milling unit

Product No.	STRA2A2202
Ref. No.	—
Speed ratio	1:1
RPM Max.	6000
Tool clamping	ER16M

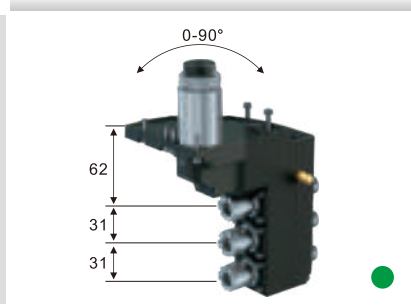

3-spindle double drilling/milling unit

Product No.	STRA2B3202
Ref. No.	—
Speed ratio	1:1
RPM Max.	6000
Tool clamping	ER16M/ER11M

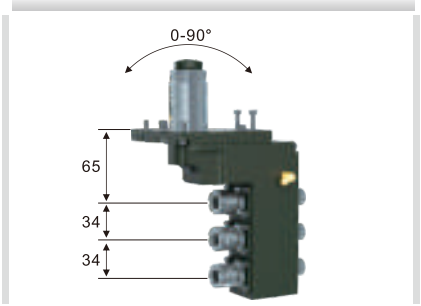

3-spindle double drilling/milling unit

Product No.	STRA2B3302
Ref. No.	—
Speed ratio	1:1
RPM Max.	6000
Tool clamping	ER16M/ER11M

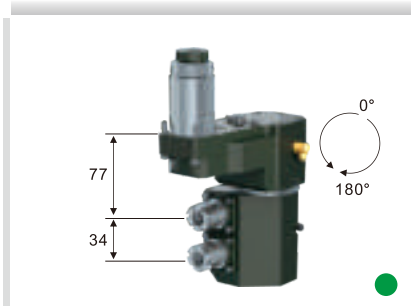

2-spindle drilling/milling unit

Product No.	STRA2A2303
Ref. No.	—
Speed ratio	1:1
RPM Max.	6000
Tool clamping	ER16M

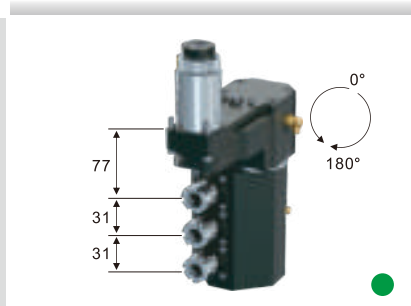

3-spindle drilling/milling unit

Product No.	STRA2A3203
Ref. No.	—
Speed ratio	1:1
RPM Max.	6000
Tool clamping	ER16M

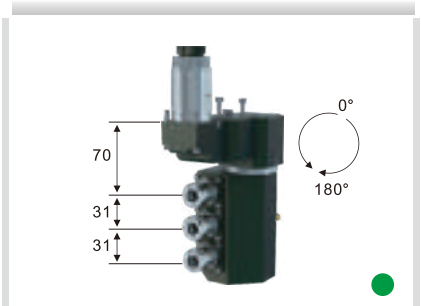

3-spindle drilling/milling unit

Product No.	STRA2A3207
Ref. No.	—
Speed ratio	1:1
RPM Max.	6000
Tool clamping	ER16M



Cross drilling/milling unit

Product No.	STRA116202 / STRA120201
Ref. No.	33150
Speed ratio	1:1
RPM Max.	8000
Tool clamping	ER16M / ER20M



Cross drilling/milling unit

Product No.	STRA116201
Ref. No.	57155
Speed ratio	1:1
RPM Max.	8000
Tool clamping	ER16M



Cross drilling/milling unit

Product No.	STRA111202
Ref. No.	—
Speed ratio	1:3
RPM Max.	18000
Tool clamping	ER11A

Symbology



Internal Coolant/BAR



Speeder



Reducer



Adjustable

STAR

ECAS, SB, SR, SW

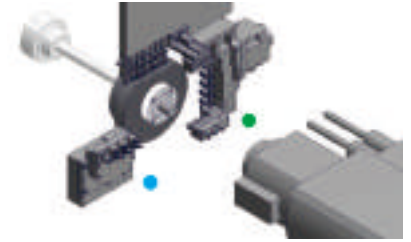

STAR



Cross drilling/milling unit, 3-spindle

Product No.	STRA111201
Ref. No.	—
Speed ratio	1:1
RPM Max.	8000
Tool clamping	ER11M



Slotting unit

Product No.	STRA712201
Ref. No.	54153
Speed ratio	1:0.374 ↓
RPM Max.	4000
Tool clamping	Ø12.7xØ50



Thread whirling unit ⬆

Product No.	STRA545203
Ref. No.	68172
Speed ratio	1:1
RPM Max.	6000
Tool clamping	Utilis no.119287

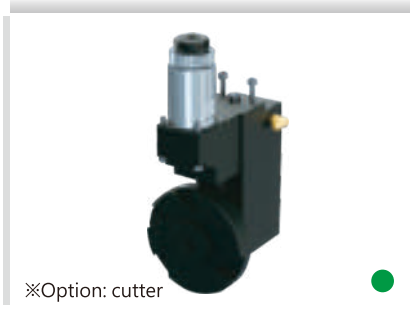

Polygon unit

Product No.	STRA400201
Ref. No.	54191
Speed ratio	1:1
RPM Max.	3000
Tool clamping	—

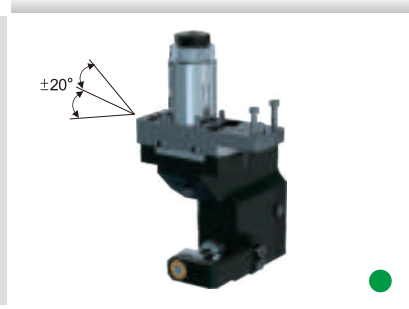

Gear hobbing unit ⬆

Product No.	STRA613201
Ref. No.	—
Speed ratio	1:1
RPM Max.	6000
Tool clamping	Ø13xØ30x20



Idler shaft

Product No.	STRA100000
Ref. No.	57189
Speed ratio	—
RPM Max.	—
Tool clamping	—



Boring bar holder

Product No.	STRA803307
Ref. No.	—
Speed ratio	—
RPM Max.	—
Tool clamping	Ø22

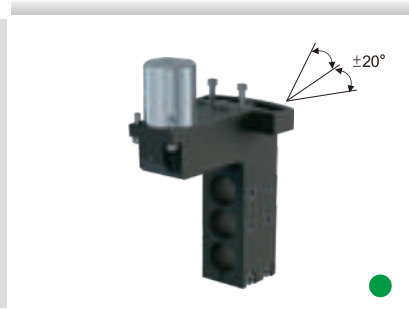

Air tool holder ⬆

Product No.	STRA0002
Ref. No.	—
Speed ratio	—
RPM Max.	—
Tool clamping	Ø22



Air tool holder

Product No.	STBA0004
Ref. No.	—
Speed ratio	—
RPM Max.	—
Tool clamping	Ø22



STAR

ECAS, SB, SR, SW

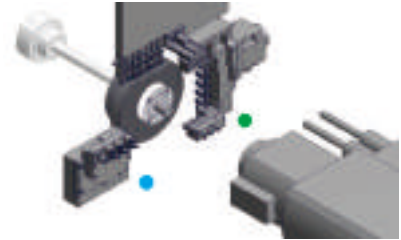

STAR



Air tool holder for sub spindle

Product No.	STRB0001
Ref. No.	–
Speed ratio	–
RPM Max.	–
Tool clamping	Ø22.8

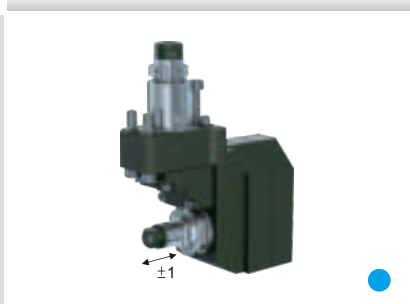

Slotting unit for sub spindle

Product No.	STRB700201
Ref. No.	69166/69165
Speed ratio	1:0.55
RPM Max.	4000
Tool clamping	Ø5/6/8/10/12.7/13xØ50

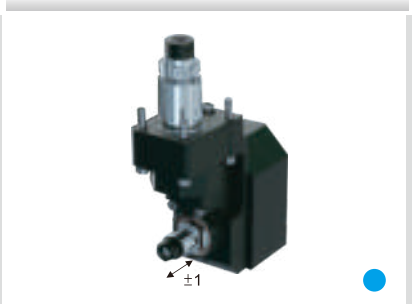

Slotting unit for sub spindle

Product No.	STRB700202
Ref. No.	0R165
Speed ratio	1:0.55
RPM Max.	4000
Tool clamping	Ø5/6/8/10/12.7/13xØ50



Drilling/milling unit for sub spindle

Product No.	STRB111208
Ref. No.	54161
Speed ratio	1:1
RPM Max.	6000
Tool clamping	ER11M



Drilling/milling unit for sub spindle

Product No.	STRB116202
Ref. No.	57161
Speed ratio	1:1
RPM Max.	6000
Tool clamping	ER16M



Drilling/milling unit for sub spindle

Product No.	STRB116201
Ref. No.	0R161
Speed ratio	1:1
RPM Max.	6000
Tool clamping	ER16M



Drilling/milling unit for sub spindle

Product No.	STRB111204
Ref. No.	–
Speed ratio	1:3
RPM Max.	18000
Tool clamping	ER11

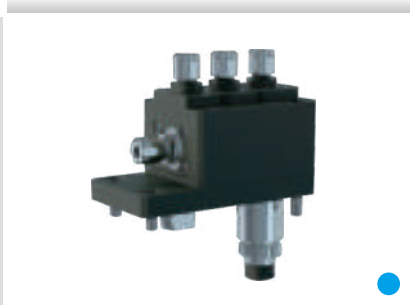

Drilling/milling unit for sub spindle, 3-spindle

Product No.	STRB108101
Ref. No.	–
Speed ratio	1:1
RPM Max.	8000
Tool clamping	ER8M



Drilling/milling unit for sub spindle, 3-spindle

Product No.	STRB111201
Ref. No.	0E151
Speed ratio	1:1
RPM Max.	8000
Tool clamping	ER11M

Symbology



Internal Coolant/BAR



Speeder



Reducer



Adjustable

STAR

ECAS, SB, SR, SW

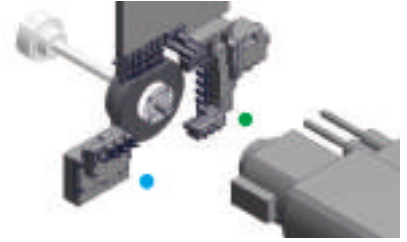

STAR

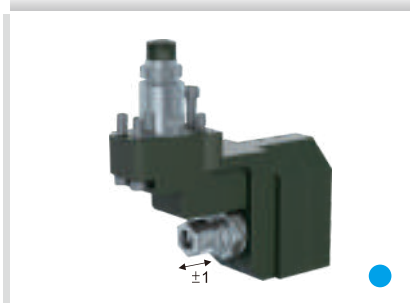

Cross drilling/milling unit for sub spindle

Product No.	STRB311201
Ref. No.	—
Speed ratio	1:0.55
RPM Max.	4000
Tool clamping	ER11A

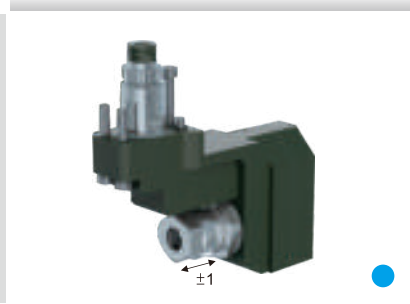

Cross drilling/milling unit for sub spindle

Product No.	STRB316202
Ref. No.	—
Speed ratio	1:0.77
RPM Max.	4000
Tool clamping	ER16A



Cross drilling/milling unit for sub spindle

Product No.	STRB316201
Ref. No.	OR151
Speed ratio	1:1
RPM Max.	6000
Tool clamping	ER16M



Cross drilling/milling unit for sub spindle

Product No.	STRB311101
Ref. No.	—
Speed ratio	1:1
RPM Max.	6000
Tool clamping	ER11

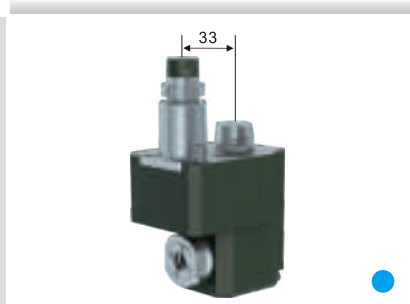

Cross drilling/milling unit for sub spindle

Product No.	STRB311204
Ref. No.	—
Speed ratio	1:1
RPM Max.	6000
Tool clamping	ER11

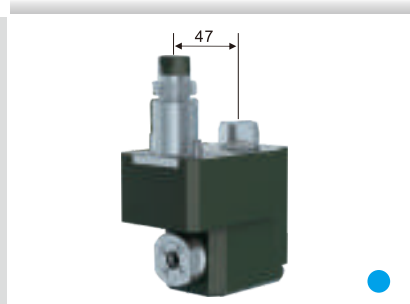

Cross drilling/milling unit for sub spindle

Product No.	STRB311301
Ref. No.	—
Speed ratio	1:1
RPM Max.	6000
Tool clamping	ER11



Cross drilling/milling unit for sub spindle

Product No.	STRB311203
Ref. No.	0E152
Speed ratio	1:1
RPM Max.	8000
Tool clamping	ER11M



Cross drilling/milling unit for sub spindle

Product No.	STRB311202
Ref. No.	—
Speed ratio	1:1
RPM Max.	6000
Tool clamping	ER11



Drilling/milling unit for sub spindle

Product No.	STRB111203
Ref. No.	—
Speed ratio	1:1
RPM Max.	8000
Tool clamping	ER11

STAR

ECAS, SB, SR, SW

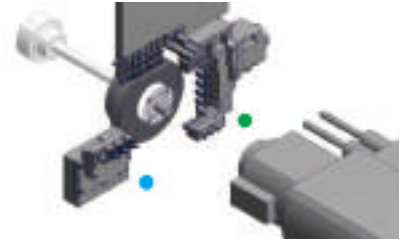

STAR

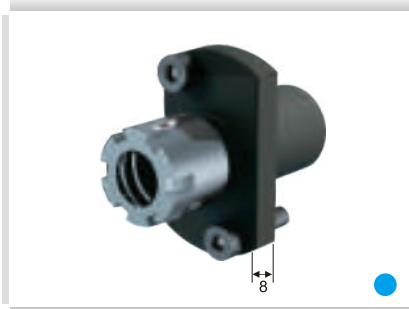

Drill holder for sub spindle

Product No.	STRB81Q309
Ref. No.	—
Speed ratio	—
RPM Max.	—
Tool clamping	ER16M

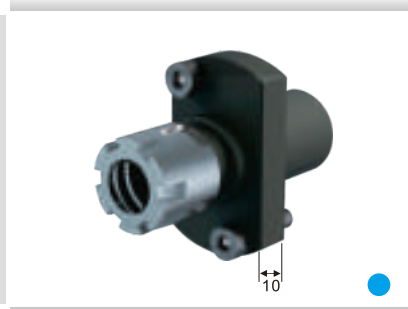

Drill holder for sub spindle

Product No.	STRB81Q307
Ref. No.	54121
Speed ratio	—
RPM Max.	—
Tool clamping	ER16M



Drill holder for sub spindle 25bar

Product No.	STRB81Q304
Ref. No.	—
Speed ratio	—
RPM Max.	—
Tool clamping	ER16M

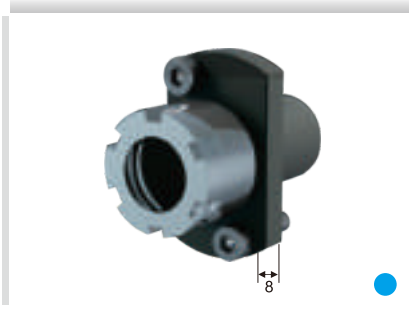

Drill holder for sub spindle

Product No.	STRB81Q305
Ref. No.	—
Speed ratio	—
RPM Max.	—
Tool clamping	ER20M



Drill holder for sub spindle

Product No.	STRB81Q313
Ref. No.	67122
Speed ratio	—
RPM Max.	—
Tool clamping	ER20M



Drill holder for sub spindle 25bar

Product No.	STRB81Q303
Ref. No.	—
Speed ratio	—
RPM Max.	—
Tool clamping	ER20M



Drill holder for sub spindle

Product No.	STRB81E201
Ref. No.	0R122
Speed ratio	—
RPM Max.	—
Tool clamping	ER16M



Drill holder for sub spindle 25bar

Product No.	STRB81E202
Ref. No.	0R123
Speed ratio	—
RPM Max.	—
Tool clamping	ER16M



Drill holder for sub spindle

Product No.	STRB81S301
Ref. No.	10119
Speed ratio	—
RPM Max.	—
Tool clamping	ER20M

Symbology

Internal Coolant/BAR Speeder Reducer Adjustable

STAR

ECAS, SB, SR, SW

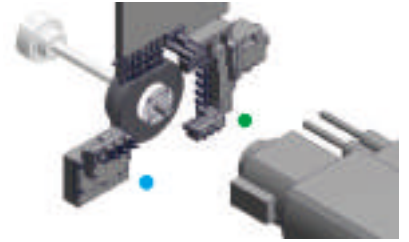

STAR



Drill holder for sub spindle

Product No.	STRB81Q101
Ref. No.	69125
Speed ratio	–
RPM Max.	–
Tool clamping	ER11M



Drill holder for sub spindle

Product No.	STRB81Q201
Ref. No.	–
Speed ratio	–
RPM Max.	–
Tool clamping	ER11M



Drill holder for sub spindle

Product No.	STRB82Q201
Ref. No.	–
Speed ratio	–
RPM Max.	–
Tool clamping	Ø16



Drill holder for sub spindle

Product No.	STRB82Q202
Ref. No.	–
Speed ratio	–
RPM Max.	–
Tool clamping	Ø16



Boring bar holder for sub spindle

Product No.	STRB82Q200
Ref. No.	–
Speed ratio	–
RPM Max.	–
Tool clamping	Ø3/4/5/6/8/9/10/12/16

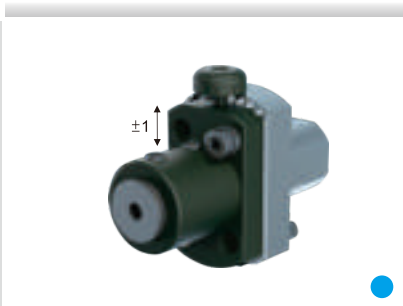

Boring bar holder for sub spindle

Product No.	STRBA22000+COMBAB0000
Ref. No.	–
Speed ratio	–
RPM Max.	–
Tool clamping	Ø3/4/5/6/8/9/10/12/16



Boring bar holder for sub spindle 25bar

Product No.	STRB82E200
Ref. No.	–
Speed ratio	–
RPM Max.	–
Tool clamping	Ø6/8/9/10/12/16

Symbology



Internal Coolant/BAR



Speeder



Reducer



Adjustable

STAR

ECAS, SB, SR, SW

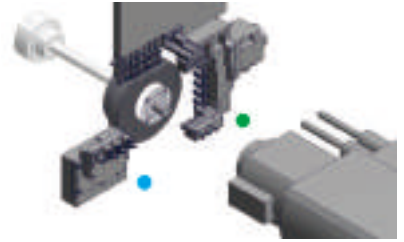

STAR

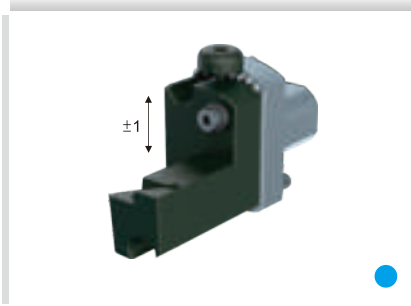

Turning holder for sub spindle

Product No.	STRBA22000+COMBADL550
Ref. No.	—
Speed ratio	—
RPM Max.	—
Tool clamping	DC.T11T3

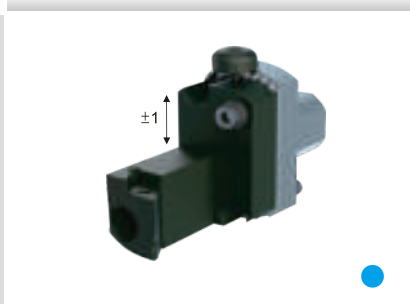

Turning holder for sub spindle

Product No.	STRBA22000+COMBADR550
Ref. No.	—
Speed ratio	—
RPM Max.	—
Tool clamping	DC.T11T3

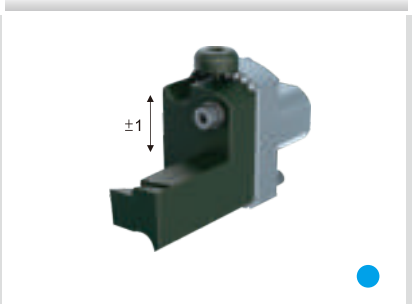

Turning holder for sub spindle

Product No.	STRBA22000+COMBADL350
Ref. No.	—
Speed ratio	—
RPM Max.	—
Tool clamping	VC.T1103



Turning holder for sub spindle

Product No.	STRB912201
Ref. No.	—
Speed ratio	—
RPM Max.	—
Tool clamping	Ø12



Turning holder for sub spindle

Product No.	STRB910202
Ref. No.	—
Speed ratio	—
RPM Max.	—
Tool clamping	□10

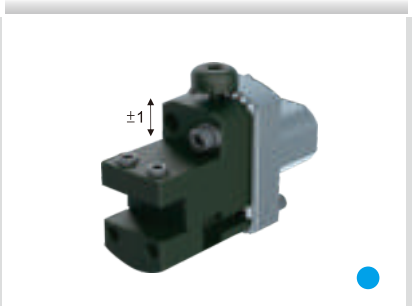

Turning holder for sub spindle

Product No.	STRBA22000+COMBAC1000
Ref. No.	—
Speed ratio	—
RPM Max.	—
Tool clamping	□10



Turning holder for sub spindle

Product No.	STRB910201
Ref. No.	—
Speed ratio	—
RPM Max.	—
Tool clamping	□10



Turning holder for sub spindle

Product No.	STRB912203
Ref. No.	—
Speed ratio	—
RPM Max.	—
Tool clamping	□12



Turning holder for sub spindle

Product No.	STRB912204
Ref. No.	—
Speed ratio	—
RPM Max.	—
Tool clamping	□12

Symbology



Internal Coolant/BAR



Speeder



Reducer



Adjustable

STAR

SV32JII, SV12, SV20, ECAS20T

STAR



Axial drilling/milling unit

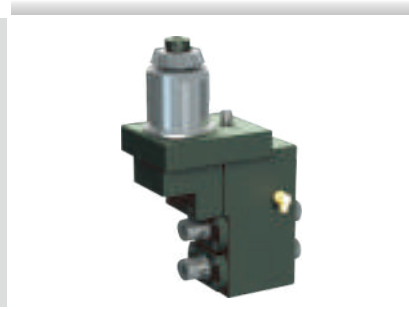

Radial drilling/milling unit

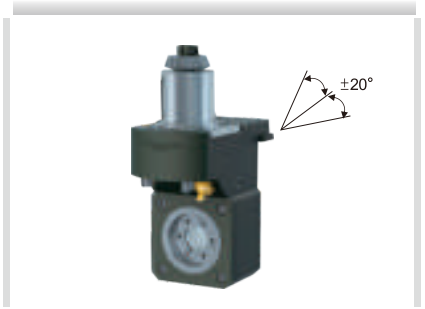

Thread whirling unit

Product No.	STVC116201	STVC2B2201	STVC545201
Ref. No.	22150	42159	—
Speed ratio	1:1	1:1.16	1:1
RPM Max.	6000	6000	6000
Tool clamping	ER16A	ER11M	Utilis no.119287



Turning holder



Turning holder

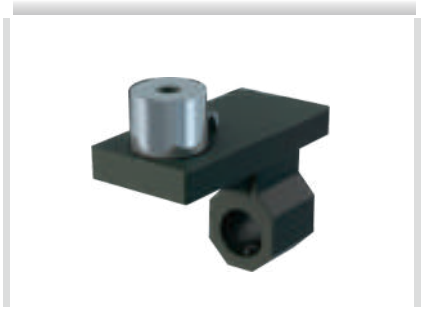

Boring bar holder

Product No.	STVC916201	STVC916202	STVC801204
Ref. No.	—	—	—
Speed ratio	—	—	—
RPM Max.	—	—	—
Tool clamping	□ 16	□ 16	Ø32

STAR

SV32, ECAS32T, SV-38R

STAR



Axial drilling/milling unit

Product No.	STVC120301
Ref. No.	58151
Speed ratio	1:1
RPM Max.	6000
Tool clamping	ER20A



Axial drilling/milling unit

Product No.	STVC116301
Ref. No.	43151
Speed ratio	1:1
RPM Max.	6000
Tool clamping	ER16A



Radial drilling/milling unit

Product No.	STVC2B2301
Ref. No.	—
Speed ratio	1:1.16 
RPM Max.	6000
Tool clamping	ER11M

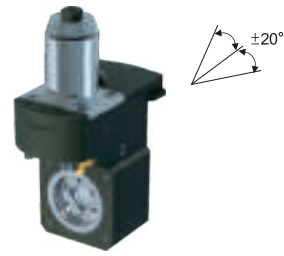

Thread whirling unit 

Product No.	STVC545301
Ref. No.	—
Speed ratio	1:1
RPM Max.	6000
Tool clamping	Utilis no.119287

SG42



Radial drilling/milling unit (for sub spindle)

Product No.	STGC2A2401
Ref. No.	—
Speed ratio	1:1
RPM Max.	6000
Tool clamping	ER20M



Radial drilling/milling unit (for main spindle)

Product No.	STGC2A2402
Ref. No.	—
Speed ratio	1:1
RPM Max.	6000
Tool clamping	ER20M

Symbology

 Internal Coolant/BAR  Speeder  Reducer  Adjustable

TSUGAMI

BO205

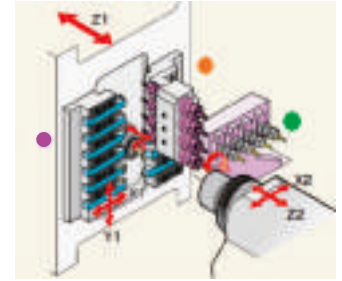

TSUGAMI



Thread whirling unit ⚙️

Product No.	TSBA545201
Ref. No.	—
Speed ratio	1:1
RPM Max.	8000
Tool clamping	Utilis no.119287



Tool holder

Product No.	TSBA0001
Ref. No.	3220-T520
Speed ratio	—
RPM Max.	—
Tool clamping	Ø20



Cross drilling/milling unit for sub spindle

Product No.	TSBB311201
Ref. No.	3220-Y7074
Speed ratio	1:1
RPM Max.	8000
Tool clamping	ER11A



Drilling/milling unit for sub spindle

Product No.	TSBB116201
Ref. No.	3220-Y7072
Speed ratio	1:1
RPM Max.	8000
Tool clamping	ER16M



Drill holder for sub spindle

Product No.	TSBB81Q202
Ref. No.	—
Speed ratio	—
RPM Max.	—
Tool clamping	ER11A



Drill holder for sub spindle

Product No.	TSBB82Q201
Ref. No.	3220-Y7073
Speed ratio	—
RPM Max.	—
Tool clamping	Ø20

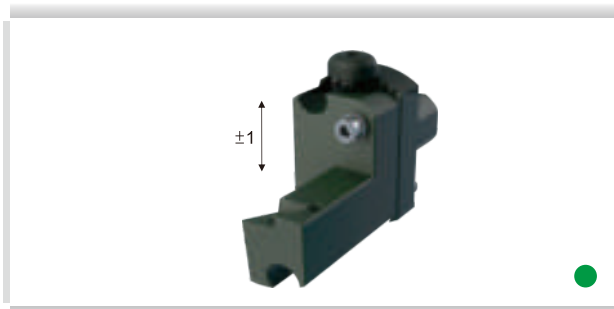

Turning holder for sub spindle ⚙️

Product No.	TSBBA20000+COMBADL550
Ref. No.	—
Speed ratio	—
RPM Max.	—
Tool clamping	DC.T11T3



Air tool holder for sub spindle

Product No.	TSBB0001
Ref. No.	—
Speed ratio	—
RPM Max.	—
Tool clamping	NR-303

TSUGAMI

BO265, BO266, BO325, BO326, BO385



TSUGAMI



Cross drilling/milling unit

Product No.	TSBA116301
Ref. No.	3268-T051
Speed ratio	1:1
RPM Max.	6000
Tool clamping	ER16A



Cross drilling/milling unit

Product No.	TSBA120301
Ref. No.	3268-T051-ER20
Speed ratio	1:1
RPM Max.	6000
Tool clamping	ER20A



Cross drilling/milling unit

Product No.	TSBA111301
Ref. No.	3290-Y670
Speed ratio	1:2
RPM Max.	12000
Tool clamping	ER11A



Cross drilling/milling unit

Product No.	TSBA116303
Ref. No.	—
Speed ratio	1:1
RPM Max.	6000
Tool clamping	ER16A



Cross drilling/milling unit, 2-spindle

Product No.	TSBA116304
Ref. No.	—
Speed ratio	1:1
RPM Max.	6000
Tool clamping	ER16A



Thread whirling unit

Product No.	TSBA545301
Ref. No.	3268-Y450
Speed ratio	1:1
RPM Max.	5000
Tool clamping	Utilis no.119287



Drilling unit (deep hole)

Product No.	TSBA116302
Ref. No.	3290-Y010
Speed ratio	1:1
RPM Max.	8000
Tool clamping	ER16A



2-spindle drilling/milling unit

Product No.	TSBA2A2304
Ref. No.	—
Speed ratio	1:1
RPM Max.	6000
Tool clamping	ER16AM

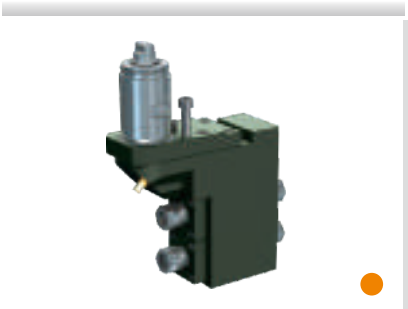

2-spindle double drilling/milling unit

Product No.	TSBA2B2303
Ref. No.	3282-Y901
Speed ratio	1:1
RPM Max.	6000
Tool clamping	ER16AM

Symbology



Internal Coolant/BAR



Speeder



Reducer



Adjustable

TSUGAMI

BO265, BO266, BO325, BO326, BO385



TSUGAMI

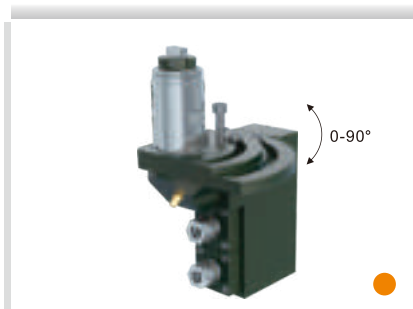

2-spindle drilling/milling unit

Product No.	TSBA2A2301
Ref. No.	—
Speed ratio	1:1
RPM Max.	6000
Tool clamping	ER16AM

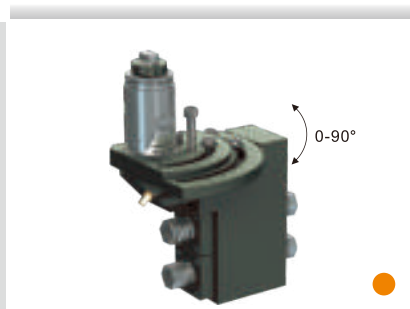

2-spindle double drilling/milling unit

Product No.	TSBA2B2302
Ref. No.	3282-Y921
Speed ratio	1:1
RPM Max.	6000
Tool clamping	ER16AM



Drilling/milling unit

Product No.	TSBA2A1301
Ref. No.	—
Speed ratio	1:1
RPM Max.	6000
Tool clamping	ER16AM

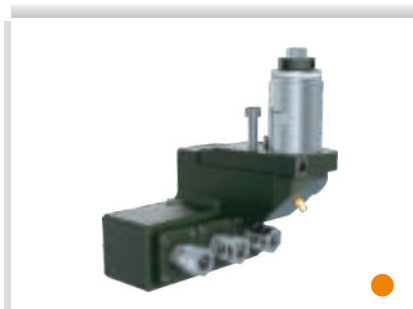

3-spindle drilling/milling unit

Product No.	TSBA2A3301
Ref. No.	—
Speed ratio	1:1
RPM Max.	5000
Tool clamping	ER16AM

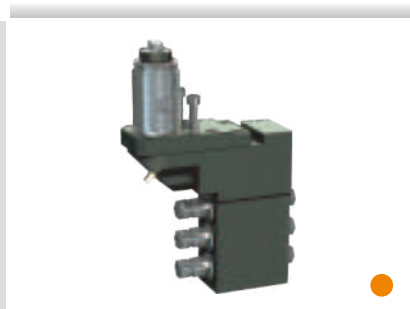

3-spindle double drilling/milling unit

Product No.	TSBA2B3302
Ref. No.	—
Speed ratio	1:1
RPM Max.	6000
Tool clamping	ER11A

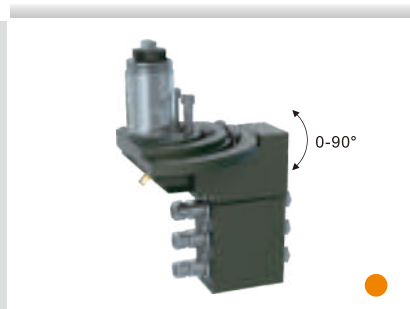

3-spindle double drilling/milling unit

Product No.	TSBA2B3301
Ref. No.	—
Speed ratio	1:1
RPM Max.	6000
Tool clamping	ER11A



Drilling/milling unit for sub spindle

Product No.	TSBB116301
Ref. No.	3282-Y041
Speed ratio	1:1
RPM Max.	6000
Tool clamping	ER16A



Drilling/milling unit for sub spindle

Product No.	TSBB111301
Ref. No.	3290-Y680
Speed ratio	1:2
RPM Max.	12000
Tool clamping	ER11A

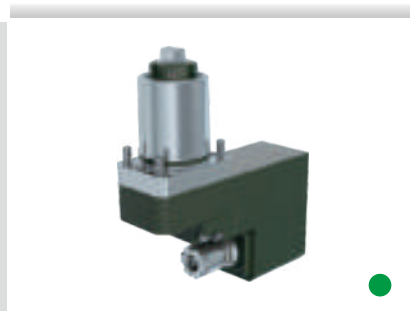

Cross drilling/milling unit for sub spindle

Product No.	TSBB316301
Ref. No.	3290-Y041
Speed ratio	1:1
RPM Max.	6000
Tool clamping	ER16M

Symbology

Internal Coolant/BAR Speeder Reducer Adjustable

TSUGAMI

BO265, BO266, BO325, BO326, BO385



TSUGAMI

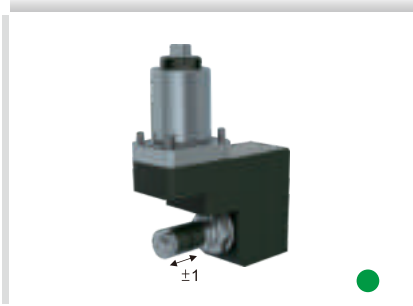

Slotting unit for sub spindle 

Product No.	TSBB712301
Ref. No.	–
Speed ratio	1:1
RPM Max.	3000
Tool clamping	Ø12.7xØ70



Drill holder for sub spindle  25bar

Product No.	TSBB82Q304
Ref. No.	3282-Y211
Speed ratio	–
RPM Max.	–
Tool clamping	Ø25



Drill holder for sub spindle

Product No.	TSBB82Q303
Ref. No.	–
Speed ratio	–
RPM Max.	–
Tool clamping	Ø25



Drill holder for sub spindle

Product No.	TSBB82Q302
Ref. No.	–
Speed ratio	–
RPM Max.	–
Tool clamping	Ø25



Drill holder for sub spindle  25bar

Product No.	TSBB81Q301
Ref. No.	–
Speed ratio	–
RPM Max.	–
Tool clamping	ER20M



Turning holder for sub spindle

Product No.	TSBB912301
Ref. No.	–
Speed ratio	–
RPM Max.	–
Tool clamping	□12



Turning holder for sub spindle

Product No.	TSBB910301
Ref. No.	–
Speed ratio	–
RPM Max.	–
Tool clamping	□10



Turning holder for sub spindle

Product No.	TSBB912302
Ref. No.	–
Speed ratio	–
RPM Max.	–
Tool clamping	□12



Boring bar holder for sub spindle 

Product No.	TSBBA42000+COMBAB0000
Ref. No.	–
Speed ratio	–
RPM Max.	–
Tool clamping	Ø3/4/5/6/8/9/10/12/16

Symbology

 Internal Coolant/BAR  Speeder  Reducer  Adjustable

TSUGAMI

S205, S206

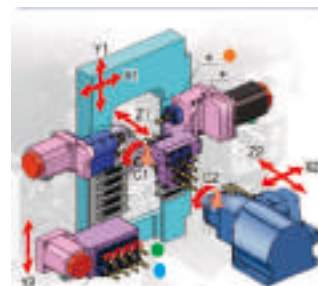

Cross drilling/milling unit

Product No.	TSSA116201
Ref. No.	3281-T050
Speed ratio	1:1
RPM Max.	8000
Tool clamping	ER16M

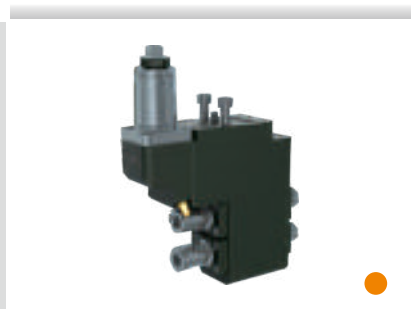

2-spindle double drilling/milling unit

Product No.	TSSA2B2201
Ref. No.	3281-Y240
Speed ratio	1:1
RPM Max.	8000
Tool clamping	ER16M/ER11A

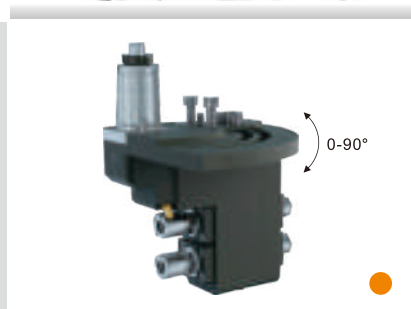

2-spindle double drilling/milling unit

Product No.	TSSA2B2202
Ref. No.	3281-Y280
Speed ratio	1:1
RPM Max.	8000
Tool clamping	ER16M/ER11A

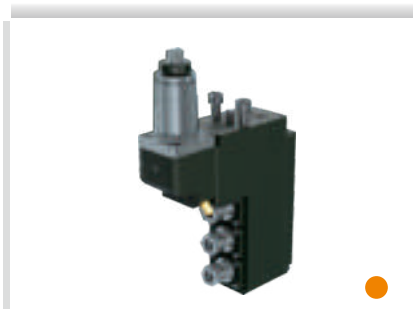

3-spindle drilling/milling unit

Product No.	TSSA2A3201
Ref. No.	—
Speed ratio	1:1
RPM Max.	8000
Tool clamping	ER11A



3-spindle drilling/milling unit

Product No.	TSSA2A3202
Ref. No.	—
Speed ratio	1:1
RPM Max.	8000
Tool clamping	ER16A

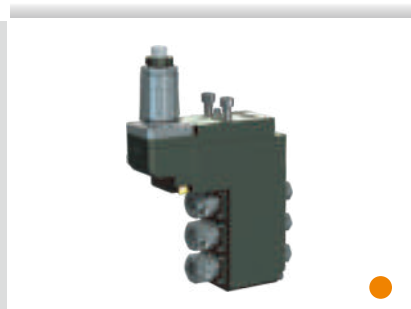

3-spindle double drilling/milling unit

Product No.	TSSA2B3201
Ref. No.	—
Speed ratio	1:1
RPM Max.	8000
Tool clamping	ER16A/ER11A

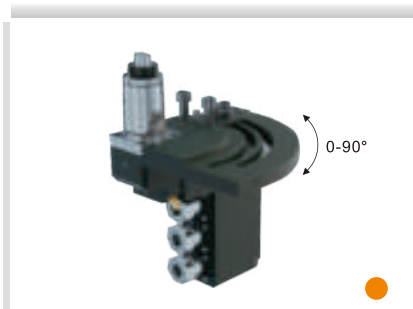

3-spindle drilling/milling unit

Product No.	TSSA2A3203
Ref. No.	—
Speed ratio	1:1
RPM Max.	8000
Tool clamping	ER16A

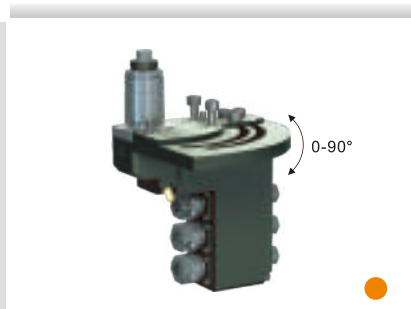

3-spindle double drilling/milling unit

Product No.	TSSA2B3202
Ref. No.	—
Speed ratio	1:1
RPM Max.	8000
Tool clamping	ER16A/ER11A



Thread whirling unit

Product No.	TSSA545201
Ref. No.	3281-Y450
Speed ratio	1:1
RPM Max.	5000
Tool clamping	Utilis no.119287

TSUGAMI

S205, S206

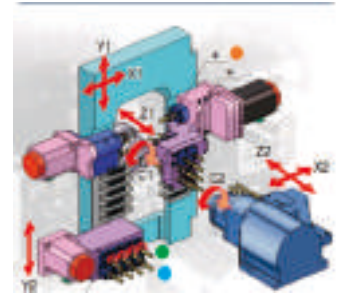

TSUGAMI



Cross drilling/milling unit for sub spindle

Product No.	TSSB316201
Ref. No.	3281-Y460
Speed ratio	1:1
RPM Max.	6000
Tool clamping	ER16M



Drilling/milling unit for sub spindle

Product No.	TSSB116201
Ref. No.	3281-S080
Speed ratio	1:1
RPM Max.	8000
Tool clamping	ER16M



Drill holder for sub spindle

Product No.	TSSB82Q202 / TSSB82Q205
Ref. No.	3281-S060
Speed ratio	—
RPM Max.	—
Tool clamping	Ø20 / Ø16



Drill holder for sub spindle  25bar

Product No.	TSSB81Q202
Ref. No.	—
Speed ratio	—
RPM Max.	—
Tool clamping	ER16M



Drill holder for sub spindle  25bar

Product No.	TSSB81Q201
Ref. No.	—
Speed ratio	—
RPM Max.	—
Tool clamping	ER20M



Drill holder for sub spindle

Product No.	TSSB82Q203
Ref. No.	—
Speed ratio	—
RPM Max.	—
Tool clamping	Ø20



Turning holder for sub spindle

Product No.	TSSB912201
Ref. No.	—
Speed ratio	—
RPM Max.	—
Tool clamping	□12

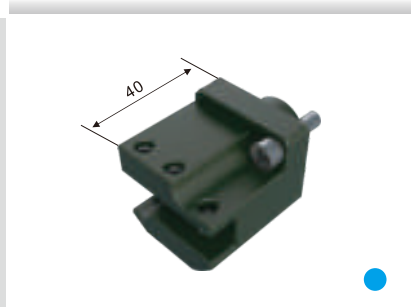

Turning holder for sub spindle

Product No.	TSSB910201
Ref. No.	—
Speed ratio	—
RPM Max.	—
Tool clamping	□10

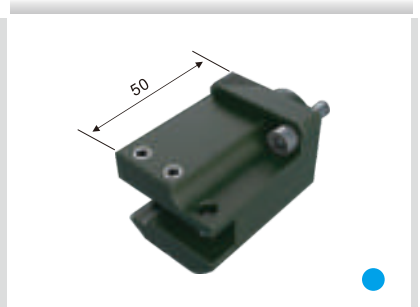

Turning holder for sub spindle

Product No.	TSSB910202
Ref. No.	—
Speed ratio	—
RPM Max.	—
Tool clamping	□10

Symbology



Internal Coolant/BAR



Speeder



Reducer



Adjustable

TSUGAMI

M06, M08

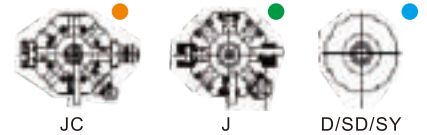

TSUGAMI



Axial drilling/milling unit

Product No.	TSMC125001
Ref. No.	3295-Z92511-0101
Speed ratio	1:1
RPM Max.	6000
Tool clamping	ER25UM



Radial drilling/milling unit

Product No.	TSMC2A2001
Ref. No.	—
Speed ratio	1:1
RPM Max.	5000
Tool clamping	ER20A



Turning holder (cut-off)

Product No.	TSMC925001
Ref. No.	3295-H260
Speed ratio	—
RPM Max.	—
Tool clamping	□25



Turning holder

Product No.	TSMC925002
Ref. No.	3295-H210
Speed ratio	—
RPM Max.	—
Tool clamping	□25



Boring bar holder

Product No.	TSMC801001
Ref. No.	3295-H202
Speed ratio	—
RPM Max.	—
Tool clamping	Ø32



Boring bar holder

Product No.	TSMC802001
Ref. No.	—
Speed ratio	—
RPM Max.	—
Tool clamping	Ø25



Boring bar holder

Product No.	TSMC802004
Ref. No.	3297-H020
Speed ratio	—
RPM Max.	—
Tool clamping	Ø25



Boring bar holder (offset, for main spindle)

Product No.	TSMC802003
Ref. No.	3295-H270
Speed ratio	—
RPM Max.	—
Tool clamping	Ø25



Boring bar holder (offset, for sub spindle)

Product No.	TSMC802002
Ref. No.	3295-H280
Speed ratio	—
RPM Max.	—
Tool clamping	Ø25



Boring bar holder (offset, for sub spindle)

Product No.	TSMC802007
Ref. No.	—
Speed ratio	—
RPM Max.	—
Tool clamping	Ø25

Symbology



CINCOM

M32



Axial drilling/milling unit

Product No.	CTMC116302
Ref. No.	KSC110
Speed ratio	1:1
RPM Max.	5000
Tool clamping	ER16A

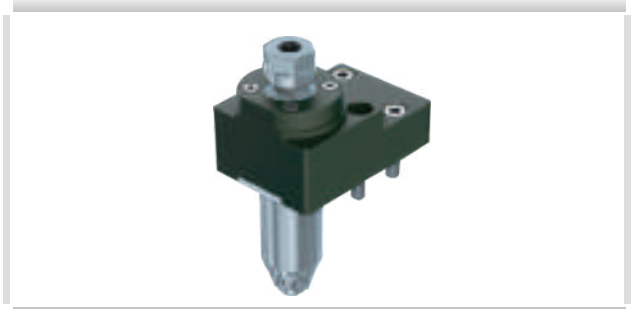

Axial drilling/milling unit

Product No.	CTMC116301
Ref. No.	KSC110-2X
Speed ratio	1:2 
RPM Max.	10000
Tool clamping	ER16A



Radial drilling/milling unit

Product No.	CTMC2A1301
Ref. No.	KSE110
Speed ratio	1:1
RPM Max.	6000
Tool clamping	ER16A

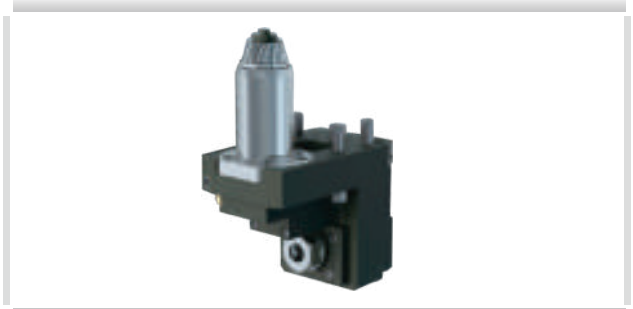

Radial drilling/milling unit

Product No.	CTMC2A1302
Ref. No.	KSE310
Speed ratio	1:1
RPM Max.	6000
Tool clamping	ER16A

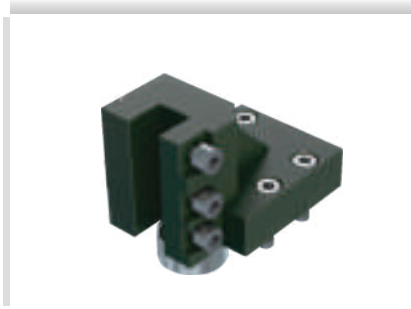

Turning holder

Product No.	CTMC916301
Ref. No.	CTF116
Speed ratio	–
RPM Max.	–
Tool clamping	<input type="checkbox"/> 16



Boring bar holder

Product No.	CTMC801301
Ref. No.	CDF101
Speed ratio	–
RPM Max.	–
Tool clamping	Ø25.4



Boring bar holder

Product No.	CTMC802301
Ref. No.	CDF401
Speed ratio	–
RPM Max.	–
Tool clamping	Ø25.4

CINCOM

M16



Axial drilling/milling unit

Product No.	CTMC111102
Ref. No.	MSC107BT
Speed ratio	1:1
RPM Max.	6000
Tool clamping	ER11A



Axial drilling/milling unit

Product No.	CTMC111101
Ref. No.	MSC106
Speed ratio	1:1
RPM Max.	6000
Tool clamping	ER11A



Axial drilling/milling unit

Product No.	CTMC111103
Ref. No.	MSC407
Speed ratio	1:1
RPM Max.	6000
Tool clamping	ER11A

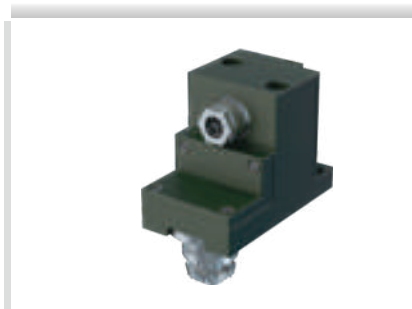

Radial drilling/milling unit

Product No.	CTMC2A1102
Ref. No.	MSE106
Speed ratio	1:1
RPM Max.	4000
Tool clamping	ER11A



Radial drilling/milling unit

Product No.	CTMC2A1103
Ref. No.	MST306
Speed ratio	1:1
RPM Max.	3000
Tool clamping	ER11A



Slotting unit

Product No.	CTMC712101
Ref. No.	MSS345
Speed ratio	1:1
RPM Max.	4000
Tool clamping	Ø12.7xØ70



Turning holder

CTMC910101
VTF110
□ 10



Turning holder (cut-off)

CTMC910102
VTF1310
□ 10



Boring bar holder

CTMC801102
VDF201
Ø19.05



Boring bar holder

CTMC801101
VDF501
Ø19.05



Boring bar holder

CTMC802101
VDF401
Ø19.05

CINCOM

L Series

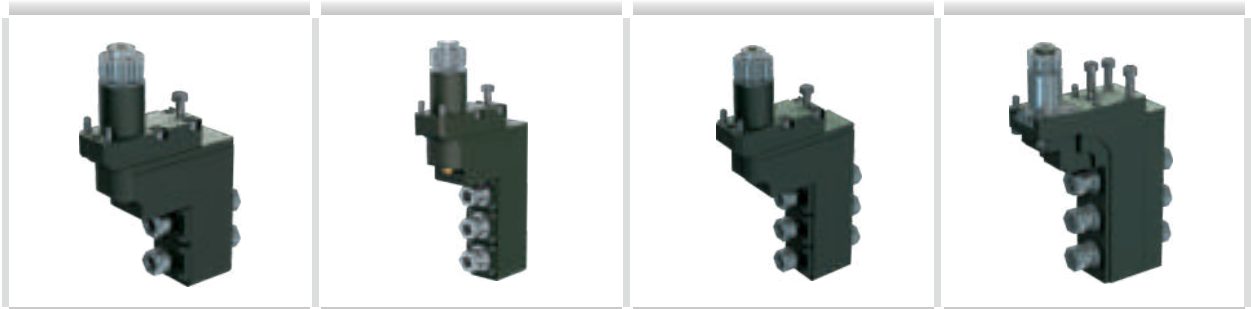

2-spindle double drilling/milling unit

3-spindle drilling/milling unit

3-spindle double drilling/milling unit

3-spindle double drilling/milling unit

Product No.	CTLA2B2301	CTLA2A3301	CTLA2B3302	CTLA2B3301
Ref. No.	–	BSE307/BSE407/BSE607	BSE507/BSE707	GSE1810
Speed ratio	1:1	1:1	1:1	1:1
RPM Max.	6000	6000	6000	6000
Tool clamping	ER11A	ER11A	ER11A	ER16AM

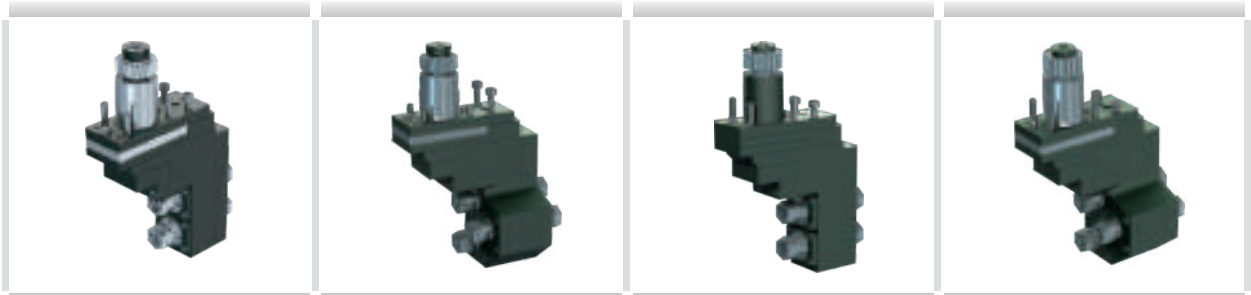

2-spindle double drilling/milling unit

3-spindle double drilling/milling unit

2-spindle double drilling/milling unit

3-spindle double drilling/milling unit

Product No.	CTLA2B2201	CTLA2B3202	CTLA2B2202	CTLA2B3206
Ref. No.	GSE3107	GSE3207	GSE3707	GSE3807
Speed ratio	1:1	1:1	1:1	1:1
RPM Max.	6000	6000	6000	6000
Tool clamping	ER11A	ER11A	ER11A	ER11A



Drilling/milling unit

3-spindle double drilling/milling unit 

Thread whirling unit 

Product No.	CTLA2A3202	CTLA2B3101	CTLA545201
Ref. No.	GSE3210	GSE3607	–
Speed ratio	1:1	1:1	1:1
RPM Max.	–	8000	6000
Tool clamping	Ø31	ER11A	Utilis no.119287

CINCOM

L Series

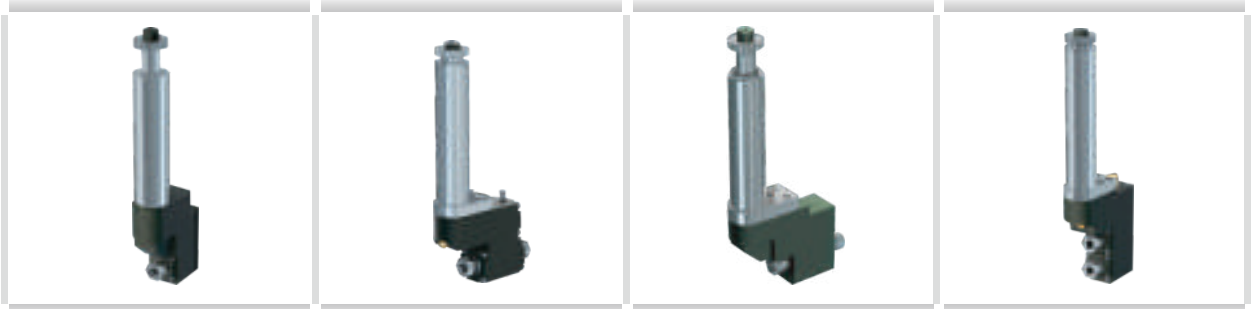

	Drilling/milling unit	Double drilling/milling unit	Double drilling/milling unit	2-spindle drilling/milling unit
Product No.	CTLA2A1201	CTLA2B1302	CTLA2B1201	CTLA2A2202
Ref. No.	–	–	–	–
Speed ratio	1:1	1:3	1:1	1:1
RPM Max.	6000	15000	6000	8000
Tool clamping	ER11A	ER11A	ER11A/ER11M	ER11A



	3-spindle drilling/milling unit	3-spindle double drilling/milling unit	3-spindle double drilling/milling unit	3-spindle drilling/milling unit
Product No.	CTLA2A3204	CTLA2B3203	CTLA2B3204	CTLA2A3201
Ref. No.	–	–	GSE1007	GSE910
Speed ratio	1:1	1:1	1:1	1:1
RPM Max.	8000	8000	4000	4000
Tool clamping	ER11A	ER11A/ER11M	ER11A	ER16M

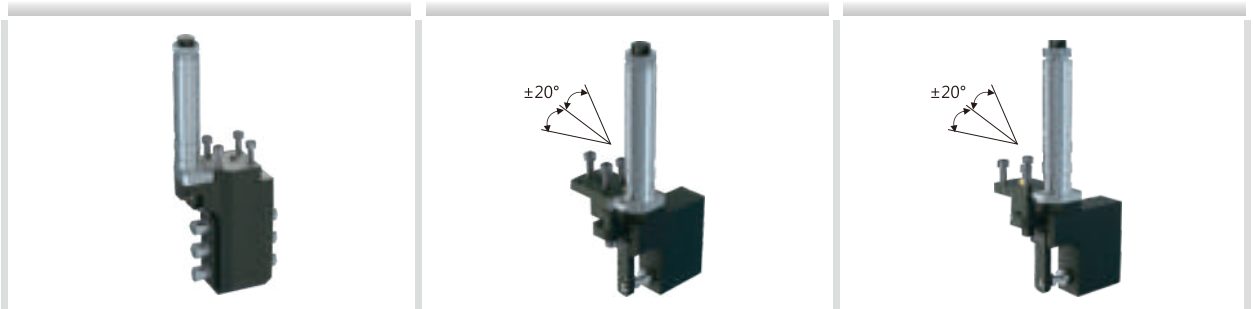

	3-spindle double drilling/milling unit	Gear hobbing unit	Gear hobbing unit
Product No.	CTLA2B3205	CTLA608202	CTLA608201
Ref. No.	GSE1307	–	–
Speed ratio	1:1	1:1	1:1
RPM Max.	4000	6000	6000
Tool clamping	ER11A	Ø8xØ25x12	Ø8xØ25x12

CINCOM

L Series



Cross drilling/milling unit

Product No.	CTAA116201
Ref. No.	GSC1310/GSC1110
Speed ratio	1:1
RPM Max.	7000
Tool clamping	ER16AM



Cross drilling/milling unit

Product No.	CTLA116201
Ref. No.	GSC1210
Speed ratio	1:1
RPM Max.	8000
Tool clamping	ER16M



Cross drilling/milling unit

Product No.	CTLA116203
Ref. No.	GSC1210
Speed ratio	1:1
RPM Max.	8000
Tool clamping	ER16



Cross drilling/milling unit

Product No.	CTLA116202
Ref. No.	GSC510/GSC1010
Speed ratio	1:1
RPM Max.	8000
Tool clamping	ER16A



Cross drilling/milling unit

Product No.	CTLA116301
Ref. No.	GSC310
Speed ratio	1:1
RPM Max.	8000
Tool clamping	ER16A



Cross drilling/milling unit

Product No.	CTLA111206
Ref. No.	GSC507-3X
Speed ratio	1:3
RPM Max.	18000
Tool clamping	ER11A



Cross drilling/milling unit

Product No.	CTLA111208
Ref. No.	GSE307
Speed ratio	1:1
RPM Max.	5000
Tool clamping	ER11A



Cross drilling/milling unit

Product No.	CTLA111202
Ref. No.	GSC907
Speed ratio	1:1
RPM Max.	6000
Tool clamping	ER11A



Gear hobbing unit

Product No.	CTAA608201
Ref. No.	–
Speed ratio	1:1
RPM Max.	3000
Tool clamping	Ø8xØ25x15



CINCOM

L Series



Drilling/milling unit for sub spindle

Product No.	CTLB111202
Ref. No.	GSE3307/GSE3507/MSC507
Speed ratio	1:1
RPM Max.	8000
Tool clamping	ER11A



Cross drilling/milling unit for sub spindle

Product No.	CTLB311205
Ref. No.	GSS1330/GSS1430/GSS1530
Speed ratio	1:1
RPM Max.	6000
Tool clamping	ER11A

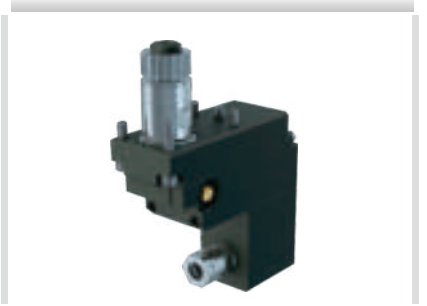

Cross drilling/milling unit for sub spindle

Product No.	CTLB316301
Ref. No.	GSE1910
Speed ratio	1:1
RPM Max.	6000
Tool clamping	ER16AM



Slotting unit for sub spindle

Product No.	CTLB700201
Ref. No.	—
Speed ratio	1:1
RPM Max.	4000
Tool clamping	Ø6/12.7xØ35

CINCOM

L Series

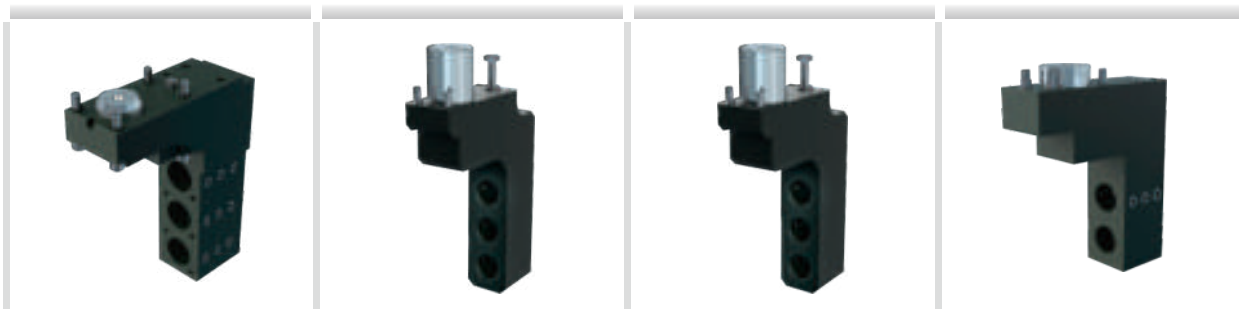

Boring bar holder

Boring bar holder

Boring bar holder

Boring bar holder

Product No.	CTLA803305	CTLA803302	CTLA803303	CTLA802202
Ref. No.	GDF1601	–	–	GDF508
Speed ratio	–	–	–	–
RPM Max.	–	–	–	–
Tool clamping	Ø25.4	Ø19.05	Ø20	Ø19.05

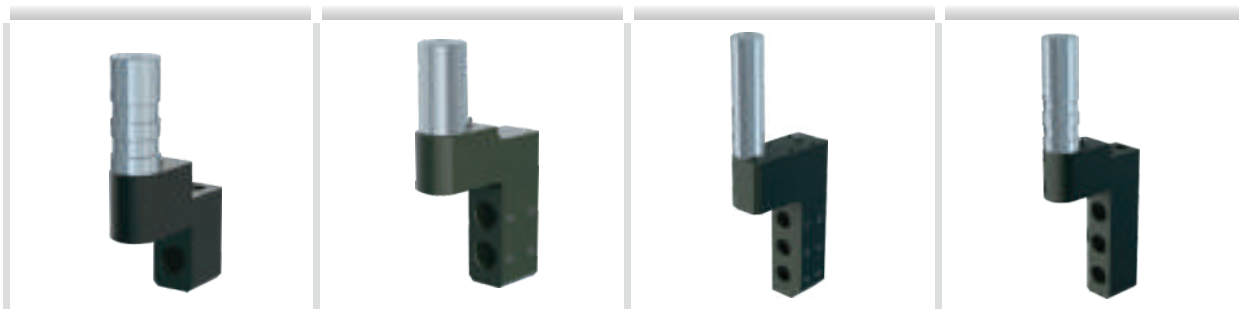

Boring bar holder

Boring bar holder

Boring bar holder

Boring bar holder

Product No.	CTLA801201	CTLA802201	CTLA803202	CTLA803203/CTLA803210
Ref. No.	GDF506	–	–	–
Speed ratio	–	–	–	–
RPM Max.	–	–	–	–
Tool clamping	Ø19.05	Ø19.05	Ø19.05	Ø19.05 / Ø20

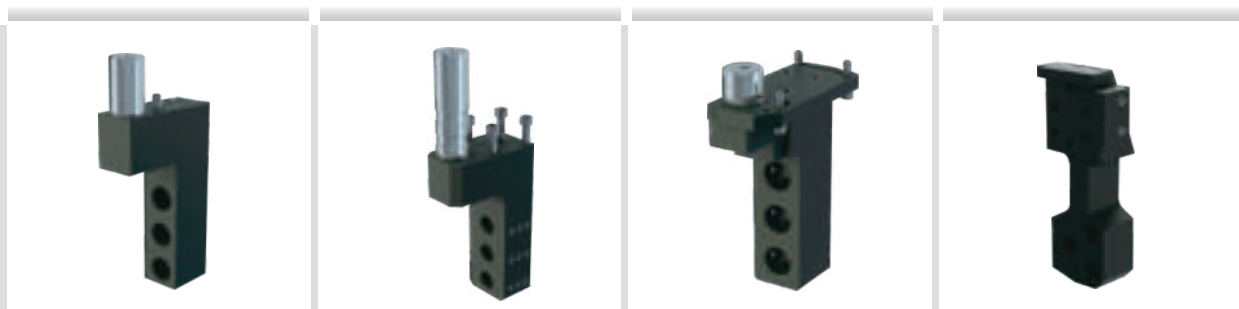

Boring bar holder

Boring bar holder

Boring bar holder

Boring bar holder

Product No.	CTLA803204/CTLA803206	CTLA803205	CTLA803101	CTLA803201
Ref. No.	GDF507	–	–	GDF607
Speed ratio	–	–	–	–
RPM Max.	–	–	–	–
Tool clamping	Ø19.05 / Ø20	Ø20	Ø19.05	Ø19.05

CINCOM

Symbology



Internal Coolant/BAR



Speeder



Reducer



Adjustable

CINCOM

L Series



Turning holder

Product No.	CTLA900055
Ref. No.	GTF3712
Speed ratio	–
RPM Max.	–
Tool clamping	DC.T1103



Turning holder

Product No.	CTLA900035
Ref. No.	–
Speed ratio	–
RPM Max.	–
Tool clamping	VC.T1103



Turning holder

Product No.	CTLA900060
Ref. No.	–
Speed ratio	–
RPM Max.	–
Tool clamping	TGF32R 175 PR930



Turning holder

Product No.	CTLA910101
Ref. No.	–
Speed ratio	–
RPM Max.	–
Tool clamping	<input type="checkbox"/> 10



Turning holder

Product No.	CTLA912301
Ref. No.	–
Speed ratio	–
RPM Max.	–
Tool clamping	<input type="checkbox"/> 12



Turning holder

Product No.	CTLA912201
Ref. No.	GTF6312
Speed ratio	–
RPM Max.	–
Tool clamping	<input type="checkbox"/> 12



Turning holder for sub spindle

Product No.	CTLB912301
Ref. No.	–
Speed ratio	–
RPM Max.	–
Tool clamping	<input type="checkbox"/> 12



Turning holder for sub spindle

Product No.	CTLBA25000+COMBADL550
Ref. No.	–
Speed ratio	–
RPM Max.	–
Tool clamping	DC.T11T3



Boring bar holder for sub spindle

Product No.	CTLBA25000+COMBAB0000
Ref. No.	–
Speed ratio	–
RPM Max.	–
Tool clamping	Ø3/4/5/6/8/9/10/12/16

CINCOM

A Series

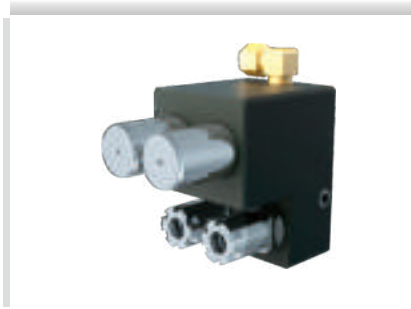

Drill holder (deep hole)



3-spindle double drilling/milling unit

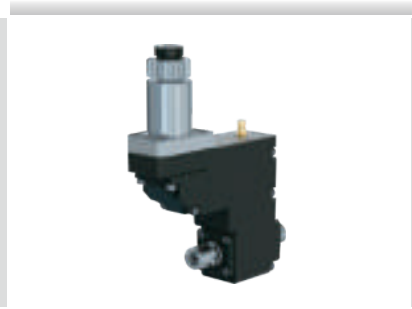

Double drilling/milling unit

Product No.	CTAA802201	CTAA2B3301	CTAA2B1201
Ref. No.	–	GSE1710	BSE107
Speed ratio	–	1:1	1:1
RPM Max.	–	4000	4000
Tool clamping	ER16M	ER16AM	ER11M

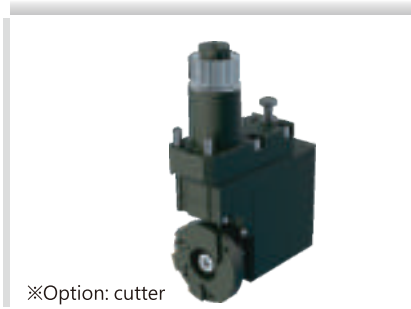

※Option: cutter

Polygon unit

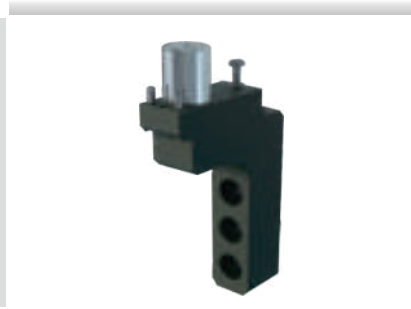

Boring bar holder

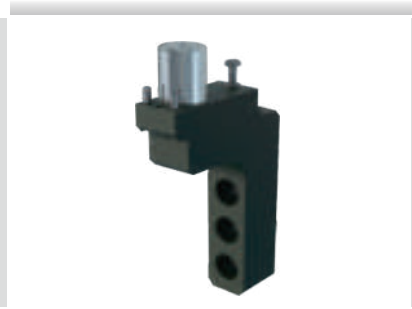

Boring bar holder

Product No.	CTAA400201	CTAA803201	CTAA803202
Ref. No.	–	–	–
Speed ratio	1:1	–	–
RPM Max.	5000	–	–
Tool clamping	–	Ø20	Ø19.05

MIYANO

BND, BNE, BNJ, ABX

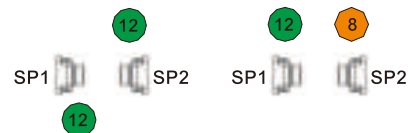

Axial drilling/milling unit

Product No.	BM45MI1A0101
Ref. No.	2W785600
Speed ratio	1:1
RPM Max.	6000
Tool clamping	ER20A



Axial drilling/milling unit

Product No.	BM45MI1A0202
Ref. No.	—
Speed ratio	1:1
RPM Max.	6000
Tool clamping	ER16A



Radial drilling/milling unit IC 25bar

Product No.	BM45MI1B0101
Ref. No.	2W785550
Speed ratio	1:1
RPM Max.	6000
Tool clamping	ER20A



Axial drilling/milling unit

Product No.	BM38MI1A0103
Ref. No.	DV70B001
Speed ratio	1:1
RPM Max.	6000
Tool clamping	ER16A



Radial drilling/milling unit

Product No.	BM38MI1B0104
Ref. No.	DV70A000
Speed ratio	1:1
RPM Max.	6000
Tool clamping	ER16A



Axial drilling/milling unit

Product No.	BM45MI1A0102
Ref. No.	2K700000
Speed ratio	1:1
RPM Max.	6000
Tool clamping	ER20A



Radial drilling/milling unit IC 25bar

Product No.	BM45MI1B0102
Ref. No.	2K701000
Speed ratio	1:1
RPM Max.	4000
Tool clamping	ER20A

MIYANO

BND, BNE, BNJ, ABX

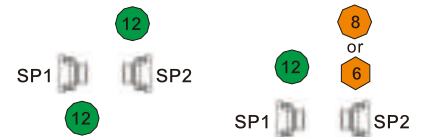

Turning holder



Turning holder



Turning holder

Product No.	BM45MI2A2001
Ref. No.	1X780100
Speed ratio	—
RPM Max.	—
Tool clamping	<input type="checkbox"/> 20

Product No.	BM45MI2A2005
Ref. No.	1X780200
Speed ratio	—
RPM Max.	—
Tool clamping	<input type="checkbox"/> 20

Product No.	BM45MI2B2002
Ref. No.	1X784100
Speed ratio	—
RPM Max.	—
Tool clamping	<input type="checkbox"/> 20



Turning holder

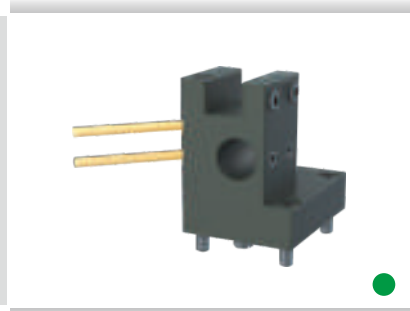

Multiple holder



Boring bar holder

Product No.	BM45MI2B2001
Ref. No.	1X784600
Speed ratio	—
RPM Max.	—
Tool clamping	<input type="checkbox"/> 20

Product No.	BM45MI2E0001
Ref. No.	1X780500
Speed ratio	—
RPM Max.	—
Tool clamping	<input type="checkbox"/> 20 Ø25

Product No.	BM45MI2D2501
Ref. No.	1X780600
Speed ratio	—
RPM Max.	—
Tool clamping	Ø25



Turning holder



Boring bar holder



Boring bar holder

Product No.	BM38MI2A2006
Ref. No.	—
Speed ratio	—
RPM Max.	—
Tool clamping	<input type="checkbox"/> 20

Product No.	BM38MI2D1501
Ref. No.	2K749001
Speed ratio	—
RPM Max.	—
Tool clamping	Ø25

Product No.	BM38MI2D2503
Ref. No.	DV73B000
Speed ratio	—
RPM Max.	—
Tool clamping	Ø25

MIYANO

MIYANO

BNA



Axial drilling/milling unit

Product No.	<u>BM38MI1A0201</u>
Ref. No.	CG70A000
Speed ratio	1:1
RPM Max.	8000
Tool clamping	ER16A



Axial drilling/milling unit

Product No.	BM38MI1A0201
Ref. No.	CL70A000
Speed ratio	1:1.66
RPM Max.	6000
Tool clamping	ER11A



Radial drilling/milling unit 25bar

Product No.	BM38MI1B0102
Ref. No.	CG70C000
Speed ratio	1:1
RPM Max.	6000
Tool clamping	ER16A

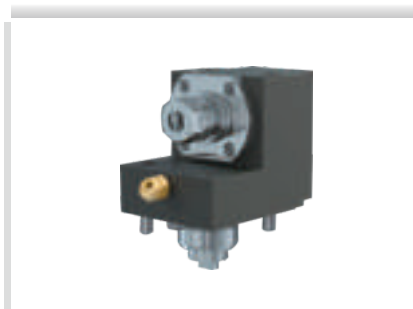

Radial drilling/milling unit

Product No.	BM38MI1B0101
Ref. No.	CG70D000
Speed ratio	1:1
RPM Max.	6000
Tool clamping	ER16A



Radial drilling/milling unit

Product No.	BM38MI1B0202
Ref. No.	—
Speed ratio	1:1
RPM Max.	6000
Tool clamping	ER11



Radial drilling/milling unit

Product No.	BM38MI1B0201
Ref. No.	CG70E000
Speed ratio	1:1
RPM Max.	6000
Tool clamping	ER16A



Turning holder (cut-off)

Product No.	BM38MI2A2001
Ref. No.	CG73C000
Speed ratio	—
RPM Max.	—
Tool clamping	□20



Turning holder

Product No.	BM38MI2A2003
Ref. No.	CG73M000
Speed ratio	—
RPM Max.	—
Tool clamping	□20



Turning holder

Product No.	BM38MI2B2001
Ref. No.	CL73A001
Speed ratio	—
RPM Max.	—
Tool clamping	□20

MIYANO

BNA



Turning holder

Product No.	BM38MI2B2002
Ref. No.	CG73L000
Speed ratio	—
RPM Max.	—
Tool clamping	□20



Boring bar holder

Product No.	BM38MI2D2501
Ref. No.	CG73P000
Speed ratio	—
RPM Max.	—
Tool clamping	Ø25



Boring bar holder

Product No.	BM38MI2D3501
Ref. No.	CG73E000
Speed ratio	—
RPM Max.	—
Tool clamping	Ø25



Boring bar holder

Product No.	BM38MI2D4501
Ref. No.	CL73B000
Speed ratio	—
RPM Max.	—
Tool clamping	Ø25

BNC



Turning holder

Product No.	BM38MI2A2005
Ref. No.	7S780100
Speed ratio	—
RPM Max.	—
Tool clamping	□20



Turning holder

Product No.	BM38MI2A2004
Ref. No.	7S780200
Speed ratio	—
RPM Max.	—
Tool clamping	□20



Axial drilling/milling unit

Product No.	BM38MI1A0102
Ref. No.	1U783000
Speed ratio	1:1
RPM Max.	6000
Tool clamping	ER16A

Symbology

Internal Coolant/BAR
 Speeder
 Reducer
 Adjustable

CHIAH CHYUN

CB Series



Gear hobbing unit

Product No.	CCBA610301
Ref. No.	—
Speed ratio	1:1
RPM Max.	6000
Tool clamping	Ø10xØ30x20



Cross drilling/milling unit, 2-spindle

Product No.	CCBA116301
Ref. No.	—
Speed ratio	1:1
RPM Max.	6000
Tool clamping	ER16A

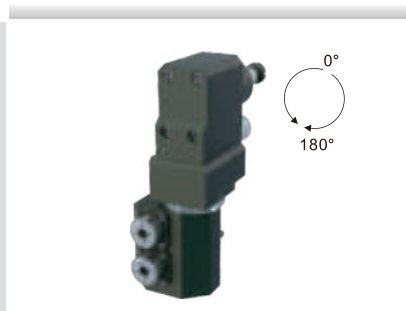

2-spindle drilling/milling unit

Product No.	CCBA2A2301
Ref. No.	—
Speed ratio	1:1
RPM Max.	6000
Tool clamping	ER11



4-spindle double drilling/milling unit

Product No.	CCBA2B4301
Ref. No.	—
Speed ratio	1:2
RPM Max.	6000
Tool clamping	ER20M*4/ER16M*4+Ø25*5



5-spindle double drilling/milling unit

Product No.	CCBA2B5301
Ref. No.	—
Speed ratio	1:2
RPM Max.	6000
Tool clamping	ER16A*5/ER11A*5+Ø25*5



5-spindle double drilling/milling unit

Product No.	CCBA2B5302
Ref. No.	—
Speed ratio	1:1
RPM Max.	6000
Tool clamping	ER16A*5/ER11A*5+Ø25*5



Slotting unit for sub spindle

Product No.	CCBB700301
Ref. No.	—
Speed ratio	1:0.75
RPM Max.	3000
Tool clamping	Ø6/12.7xØ45



Cross drilling/milling unit for sub spindle

Product No.	CCBB316301
Ref. No.	—
Speed ratio	1:1
RPM Max.	5000
Tool clamping	ER16

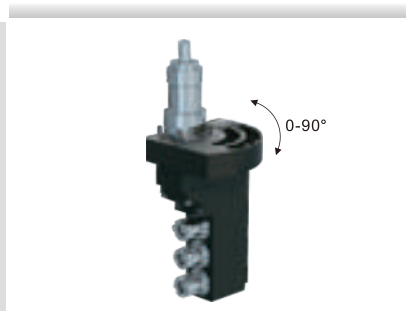

3-spindle drilling/milling unit

Product No.	CCYA2A3501
Ref. No.	—
Speed ratio	1:1
RPM Max.	5000
Tool clamping	ER16M

CHIAH CHYUN

CB



Turning holder for sub spindle



Turning holder for sub spindle

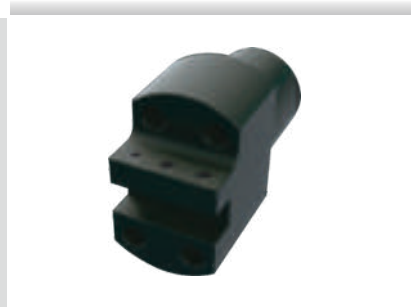

Turning holder for sub spindle

Product No.	CCBB912302	CCBB912301	CCBB916301
Ref. No.	–	–	–
Speed ratio	–	–	–
RPM Max.	–	–	–
Tool clamping	□12	□12	□16



Drill holder for sub spindle



Boring bar holder for sub spindle



Drill holder for sub spindle

Product No.	CCBB81Q302	CCBB82Q302	CCBB82Q301
Ref. No.	–	–	–
Speed ratio	–	–	–
RPM Max.	–	–	–
Tool clamping	ER20A	Ø12	Ø25

CHIAH CHYUN

CHIAH CHYUN

CT-52YM



Axial drilling/milling unit

Product No.	BM65NK1A0101
Ref. No.	—
Speed ratio	1:1
RPM Max.	6000
Tool clamping	ER32UM



Axial drilling/milling unit  30bar

Product No.	BM65NK1A0102
Ref. No.	—
Speed ratio	1:1
RPM Max.	6000
Tool clamping	ER32UM

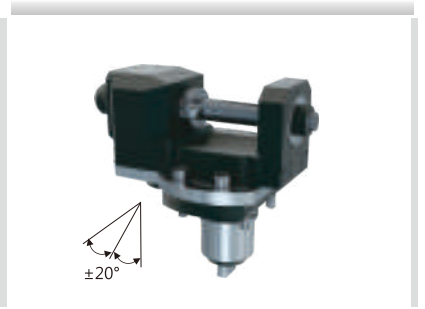

Gear hobbing unit 

Product No.	BM65NK1F2221
Ref. No.	—
Speed ratio	2:1 
RPM Max.	3000
Tool clamping	Ø22.225xØ80x80



Radial drilling/milling unit

Product No.	BM65NK1B0101
Ref. No.	—
Speed ratio	1:1
RPM Max.	6000
Tool clamping	ER32UM



Radial drilling/milling unit  30bar

Product No.	BM65NK1B0102
Ref. No.	—
Speed ratio	1:1
RPM Max.	6000
Tool clamping	ER32UM



Universal drilling/milling unit 

Product No.	BM65NK1H1801
Ref. No.	—
Speed ratio	1:1
RPM Max.	6000
Tool clamping	ER20

NOMURA

YB Series



Tool holder

Product No.	NUYA0001
Ref. No.	—
Speed ratio	—
RPM Max.	—
Tool clamping	—



Cross drilling/milling unit

Product No.	NUYA120201
Ref. No.	—
Speed ratio	1:1
RPM Max.	6000
Tool clamping	ER20M



2-spindle drilling/milling unit

Product No.	NUYA2A2301
Ref. No.	—
Speed ratio	1:1
RPM Max.	6000
Tool clamping	ER16M

SB Series

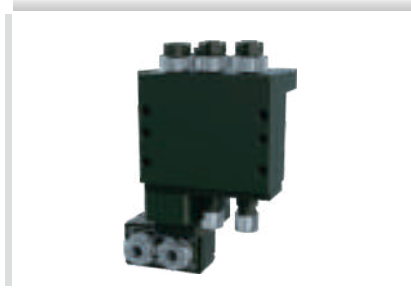

4-spindle drilling/milling unit

Product No.	NUSA2A4101
Ref. No.	—
Speed ratio	1:1
RPM Max.	6000
Tool clamping	ER11



Cross drilling/milling unit, 3-spindle

Product No.	NUSA111102
Ref. No.	—
Speed ratio	1:1
RPM Max.	6000
Tool clamping	ER11M



2-spindle drilling/milling unit

Product No.	NUSA2A2102
Ref. No.	—
Speed ratio	1:1
RPM Max.	6000
Tool clamping	ER11



Cross drilling/milling unit, 2-spindle

Product No.	NUSA116101
Ref. No.	—
Speed ratio	1.59:1
RPM Max.	6000
Tool clamping	ER16M

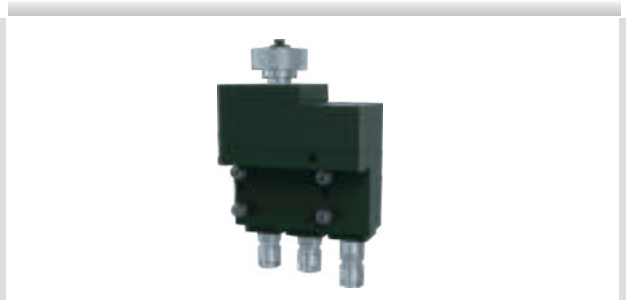

Cross drilling/milling unit, 3-spindle

Product No.	NUSA116102
Ref. No.	—
Speed ratio	1:1
RPM Max.	6000
Tool clamping	ER16M

NOMURA

UB Series



Cross drilling/milling unit

Product No.	NUUA116204
Ref. No.	—
Speed ratio	1:1
RPM Max.	6000
Tool clamping	ER16M



Cross drilling/milling unit

Product No.	NUUA116201
Ref. No.	—
Speed ratio	1:1
RPM Max.	6000
Tool clamping	ER16M



Idler shaft

Product No.	NUUA100000
Ref. No.	—
Speed ratio	—
RPM Max.	—
Tool clamping	—



3-spindle drilling/milling unit

Product No.	NUUA2A3202
Ref. No.	—
Speed ratio	1:1
RPM Max.	6000
Tool clamping	ER11M



Non-guide bush device

Product No.	NUU25500
Ref. No.	—
Speed ratio	—
RPM Max.	—
Tool clamping	—

Other



3-spindle drilling/milling unit

Product No.	NUJA2A3201
Ref. No.	—
Speed ratio	1:1
RPM Max.	6000
Tool clamping	ER11A



Cross drilling/milling unit 

Product No.	NUBA108201
Ref. No.	—
Speed ratio	1:1
RPM Max.	6000
Tool clamping	ER8M

NOMURA

Back Processing Static Tool Holder Shaft: Ø22, Ø23



Drill holder for sub spindle

Product No.	NUUB81Q201 / NUUB81Q203
Ref. No.	—
Speed ratio	—
RPM Max.	—
Tool clamping	ER16M



Drill holder for sub spindle

Product No.	NUYB81Q301 / NUYB81Q302
Ref. No.	—
Speed ratio	—
RPM Max.	—
Tool clamping	ER16M



Drill holder for sub spindle (deep hole)

Product No.	NUYB81Q304 / NUYB81Q303
Ref. No.	—
Speed ratio	—
RPM Max.	—
Tool clamping	ER16M



Turning holder for sub spindle

Product No.	NUUB910201 / NUUB910202
Ref. No.	—
Speed ratio	—
RPM Max.	—
Tool clamping	□10

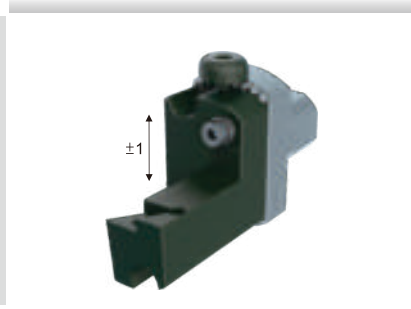

Turning holder for sub spindle

Product No.	NUUBA22000+COMBADL550
Ref. No.	—
Speed ratio	—
RPM Max.	—
Tool clamping	DC..11T3



Turning holder for sub spindle

Product No.	NUUBA22000+COMBADR550
Ref. No.	—
Speed ratio	—
RPM Max.	—
Tool clamping	DC.11T3

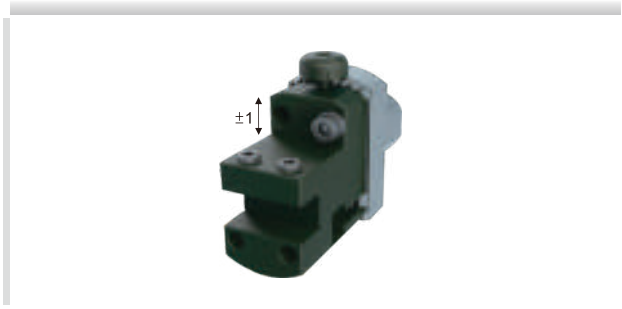

Turning holder for sub spindle

Product No.	NUUBA22000+COMBAC1000
Ref. No.	—
Speed ratio	—
RPM Max.	—
Tool clamping	□10



Reamer tool holder

Product No.	NUUA0002 / NUUA0003
Ref. No.	—
Speed ratio	—
RPM Max.	—
Tool clamping	ER11M

NOMURA

HANWHA

XD20H



Cross drilling/milling unit

Product No.	HWDA116201
Ref. No.	–
Speed ratio	1:1
RPM Max.	8000
Tool clamping	ER16A

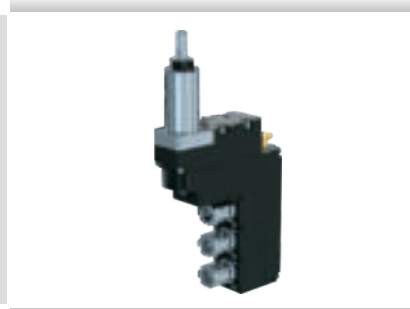

3-spindle drilling/milling unit

Product No.	HWDA2A3201
Ref. No.	–
Speed ratio	1:1
RPM Max.	6000
Tool clamping	ER16M



3-spindle double drilling/milling unit

Product No.	HWDA2B3202
Ref. No.	–
Speed ratio	1:1
RPM Max.	6000
Tool clamping	ER16M/ER11M

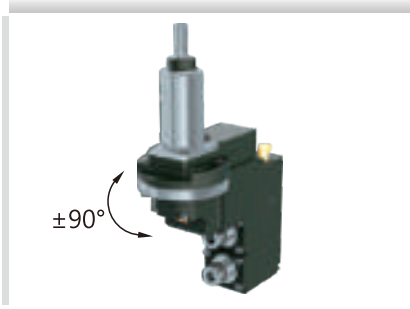

2-spindle drilling/milling unit ⚙️

Product No.	HWDA2A2203
Ref. No.	–
Speed ratio	1:1
RPM Max.	8000
Tool clamping	ER11M

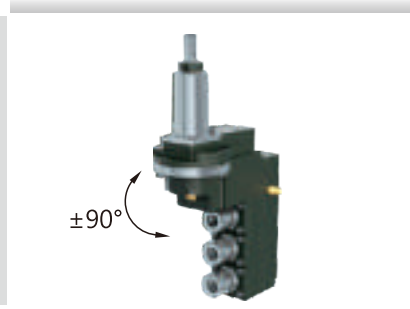

3-spindle drilling/milling unit ⚙️

Product No.	HWDA2A3202
Ref. No.	–
Speed ratio	1:1
RPM Max.	8000
Tool clamping	ER16M

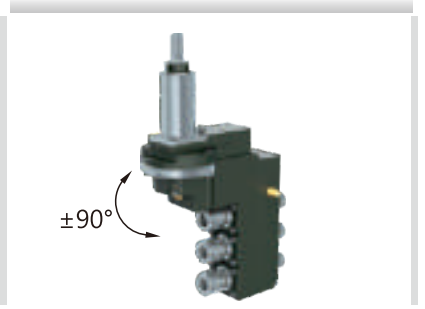

3-spindle double drilling/milling unit ⚙️

Product No.	HWDA2B3204
Ref. No.	–
Speed ratio	1:1
RPM Max.	8000
Tool clamping	ER16M/ER11M



Thread whirling unit ⚙️

Product No.	HWDA545205
Ref. No.	–
Speed ratio	1:1
RPM Max.	6000
Tool clamping	Utilis no.119287



Boring bar holder

Product No.	HWDA803201
Ref. No.	–
Speed ratio	–
RPM Max.	–
Tool clamping	Ø25



Boring bar holder

Product No.	HWDA803202
Ref. No.	–
Speed ratio	–
RPM Max.	–
Tool clamping	Ø25

HANWHA

XD20H

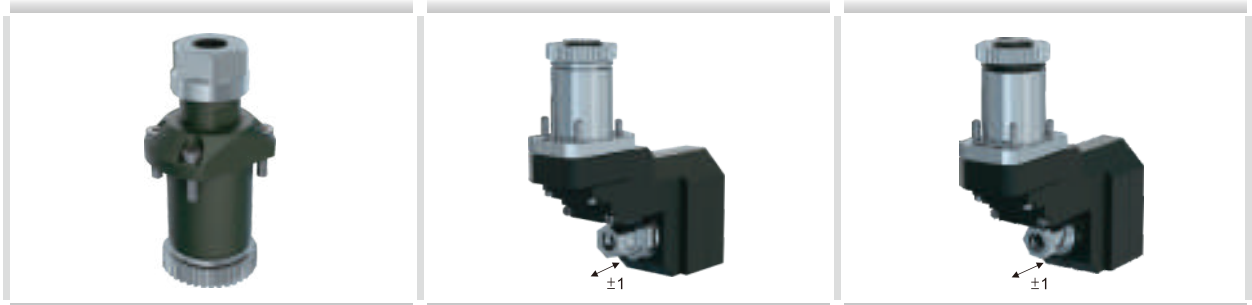

Drilling/milling unit for sub spindle

Cross drilling/milling unit for sub spindle 

Cross drilling/milling unit for sub spindle 

Product No.	HWDB116201	HWDB311201	HWDB311202
Ref. No.	—	—	—
Speed ratio	1:1	1:0.55 	1:1
RPM Max.	8000	4000	4000
Tool clamping	ER16A	ER11A	ER11A

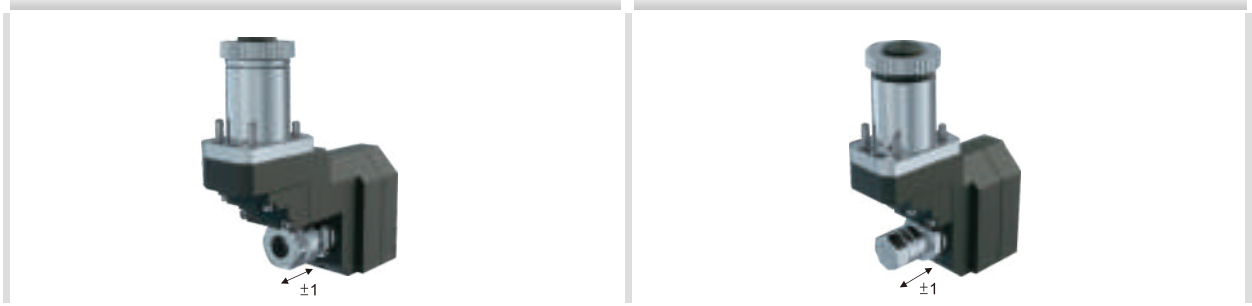

Cross drilling/milling unit for sub spindle 

Slotting unit for sub spindle 

Product No.	HWDB316202	HWDB700201
Ref. No.	—	—
Speed ratio	1:0.55 	1:0.55 
RPM Max.	4000	4000
Tool clamping	ER16A	Ø5/6/8/10/12.7/13xØ50

XD20HII

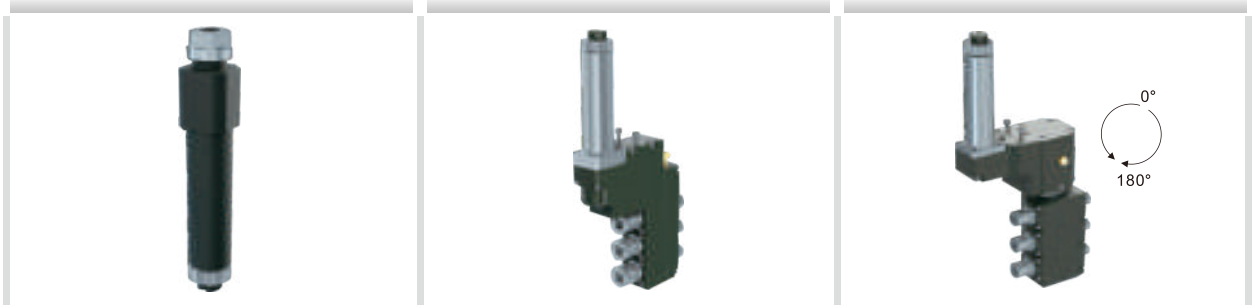

Cross drilling/milling unit

3-spindle double drilling/milling unit

3-spindle double drilling/milling unit 

Product No.	HWDA116202	HWDA2B3207	HWDA2B3208
Ref. No.	—	—	—
Speed ratio	1:1	1:1	1:1
RPM Max.	6000	6000	8000
Tool clamping	ER16A	ER16M/ER11M	ER11M/ER8M

Symbology



Internal Coolant/BAR



Speeder



Reducer



Adjustable

HANWHA

XD32H

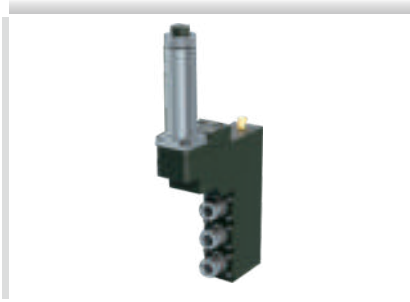

3-spindle drilling/milling unit

Product No.	HWDA2A3302
Ref. No.	—
Speed ratio	1:1
RPM Max.	6000
Tool clamping	ER16M

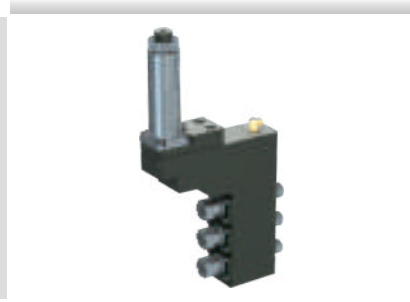

3-spindle double drilling/milling unit

Product No.	HWDA2B3302
Ref. No.	—
Speed ratio	1:1
RPM Max.	6000
Tool clamping	ER16M/ER11M

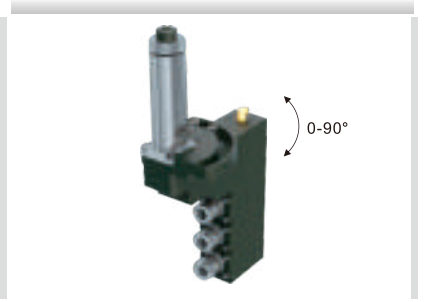

3-spindle drilling/milling unit

Product No.	HWDA2A3301
Ref. No.	—
Speed ratio	1:1
RPM Max.	6000
Tool clamping	ER16M



Cross drilling/milling unit for sub spindle

Product No.	HWDB316301
Ref. No.	—
Speed ratio	1:0.77
RPM Max.	4000
Tool clamping	ER16A



Slotting unit for sub spindle

Product No.	HWDB700301
Ref. No.	—
Speed ratio	1:0.77
RPM Max.	4000
Tool clamping	Ø5/6/8/10/12.7/13xØ60

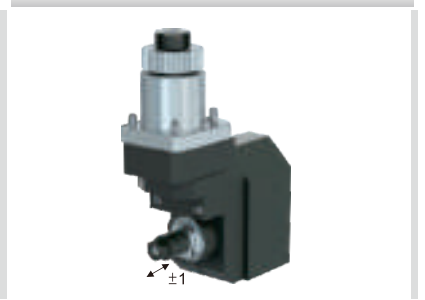

Slotting unit for sub spindle

Product No.	HWDB700302
Ref. No.	—
Speed ratio	1:0.55
RPM Max.	4000
Tool clamping	Ø5/6/8/10/12.7/13xØ50

XD12H



Slotting unit for sub spindle

Product No.	HWDB700101
Ref. No.	—
Speed ratio	1:0.55
RPM Max.	4000
Tool clamping	Ø5/6/8/10/12.7/13xØ50



Cross drilling/milling unit for sub spindle

Product No.	HWDB311101
Ref. No.	—
Speed ratio	1:0.55
RPM Max.	4000
Tool clamping	ER11A

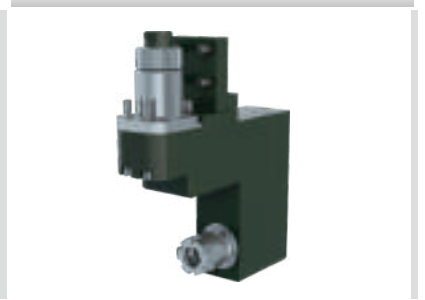

Cross drilling/milling unit for sub spindle

Product No.	HWDB316201
Ref. No.	—
Speed ratio	1:1
RPM Max.	6000
Tool clamping	ER16M

JINN FA

JSL-32AB/42AB



3-spindle double drilling/milling unit

Product No.	JSSA2B3401
Ref. No.	—
Speed ratio	1:1
RPM Max.	6000
Tool clamping	ER16M/ER11M

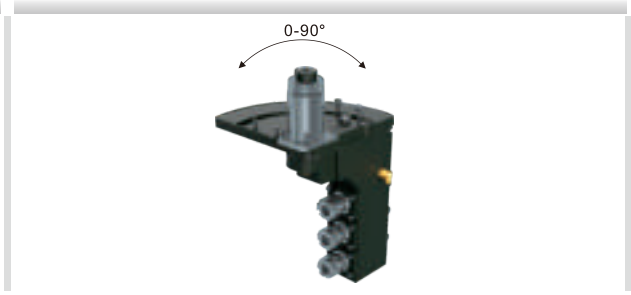

3-spindle double drilling/milling unit

Product No.	JSSA2B3402
Ref. No.	—
Speed ratio	1:1
RPM Max.	6000
Tool clamping	ER16M/ER11M

JSL-42RB/RBY



Thread whirling unit

Product No.	JSSA545401
Ref. No.	—
Speed ratio	1:1
RPM Max.	6000
Tool clamping	Utilis no.119287



Slotting unit

Product No.	JSSA712401
Ref. No.	—
Speed ratio	1:0.374
RPM Max.	4000
Tool clamping	Ø12.7xØ100

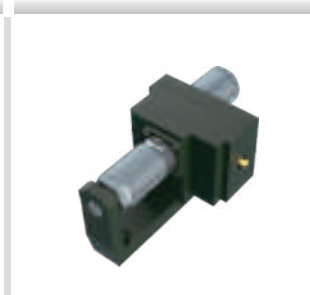

Slotting unit

Product No.	JSSA725401
Ref. No.	—
Speed ratio	1:0.374
RPM Max.	4000
Tool clamping	Ø25.4xØ110

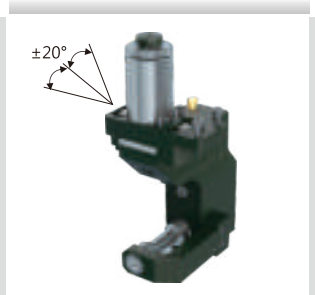

Gear hobbing unit

Product No.	JSSA616401
Ref. No.	—
Speed ratio	1:1
RPM Max.	6000
Tool clamping	Ø16xØ40x42



Drilling/milling unit for sub spindle

Product No.	JSSB120401
Ref. No.	—
Speed ratio	1:1
RPM Max.	8000
Tool clamping	ER20M

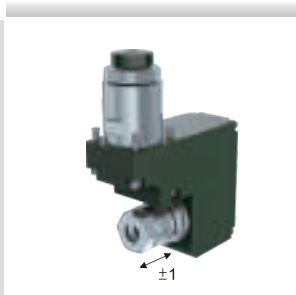

Cross drilling/milling unit for sub spindle

Product No.	JSSB316401
Ref. No.	—
Speed ratio	1:1
RPM Max.	4000
Tool clamping	ER16A



Cross drilling/milling unit for sub spindle

Product No.	JSSB316403
Ref. No.	—
Speed ratio	1:1
RPM Max.	6000
Tool clamping	ER16M



Cross drilling/milling unit for sub spindle

Product No.	JSSB316402
Ref. No.	—
Speed ratio	1:1
RPM Max.	6000
Tool clamping	ER16M

Symbology



Internal Coolant/BAR



Speeder



Reducer



Adjustable

DOOSAN

BMT-55



Axial drilling/milling unit



Radial drilling/milling unit



Turning holder (cut-off)

Product No.	BM55DS1A0101	BM55DS1B0102	BM55DS2A2501
Ref. No.	–	–	–
Speed ratio	1:1	1:1	–
RPM Max.	6000	6000	–
Tool clamping	ER25UM	ER25UM	□25



Turning holder



Turning holder



Boring bar holder

Product No.	BM55DS2A2503	BM55DS2A2502	BM55DS2D1501
Ref. No.	–	–	–
Speed ratio	–	–	–
RPM Max.	–	–	–
Tool clamping	□25	□25	Ø25



Boring bar holder

Product No.	BM55DS2D1502
Ref. No.	–
Speed ratio	–
RPM Max.	–
Tool clamping	Ø25

NAKAMURA

WT-150, AS-200 (BMT-55)



	Axial drilling/milling unit	Radial drilling/milling unit	Turning holder (cut-off)
Product No.	BM55NK1A0101	BM55NK1B0101	BM55NK2A2001
Ref. No.	–	–	–
Speed ratio	1:1	1:1	–
RPM Max.	6000	6000	–
Tool clamping	ER25UM	ER25UM	□25

WT-100, WY-100 (BMT-44)



	Turning holder	Turning holder	Boring bar holder	Boring bar holder
Product No.	BM44NK2A2001	BM44NK2B2001	BM44NK2D1501	BM44NK2D2501
Ref. No.	–	–	–	–
Speed ratio	–	–	–	–
RPM Max.	–	–	–	–
Tool clamping	□20	□20	Ø25	Ø25



CWS Werkzeugmaschinen & Service

Zeppelinstraße 12
78588 Denkingen

Tel. Verwaltung:
+49 7424 7036801

Tel. Geschäftsführung:
+49 160 7572156

info@cws-werkzeugmaschinen.de
www.cws-werkzeugmaschinen.de